



### 9,000# Dexter Sprung Axles Assembly

Made to Order

Overhang = (Hub Face - Spring Center)

Features and Options	
<b>Tubing</b>	4" OD - .250 Wall
<b>Bearings</b>	#387A Inner #25580 Outer
<b>Hub</b>	8 Lug on 6.5"
<b>Brake</b>	12-1/4" x 3-3/8" Electric 12-1/4" x 3-3/8" Hydraulic Duo Servo* <i>*ABS also available on hydraulic brake</i>
<b>Suspension</b>	Slipper Spring - 2" Wide Hanger Kit
<b>Lubrication</b>	Oil Bath (standard) or Grease (optional)

Axle Type	Min.	Max.
<b>Straight (single wheel)</b>	<b>22.00"</b>	<b>31.00"</b>
<b>Straight (dual wheel)</b>	<b>26.00"</b>	<b>31.00"</b>

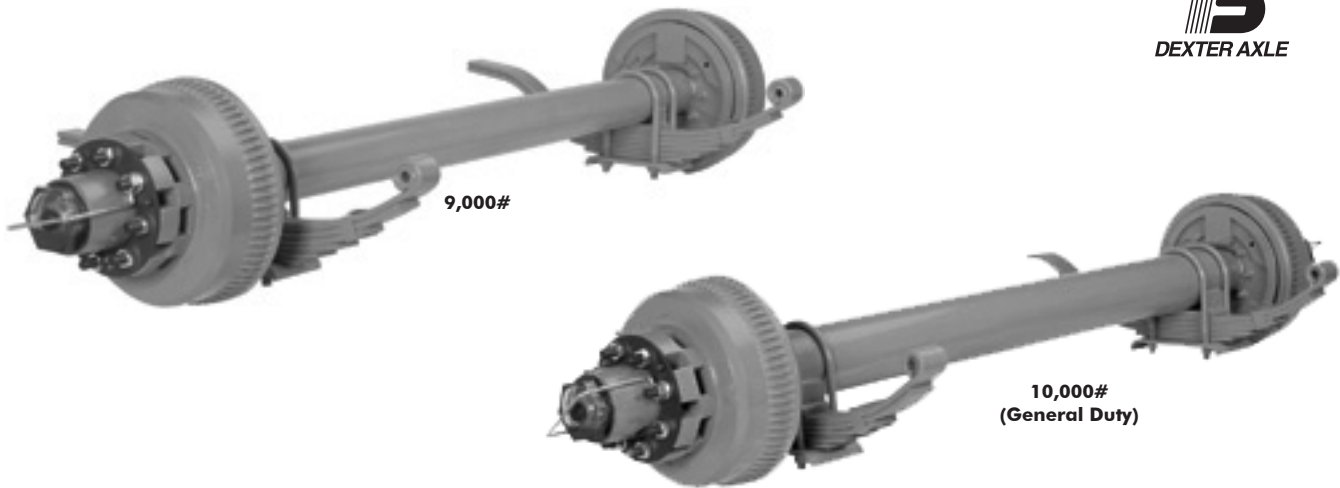

### 10,000# (General Duty) Dexter Sprung Axles Assembly

Made to Order

Overhang = (Hub Face - Spring Center)

Features and Options	
<b>Tubing</b>	5" OD - .250 Wall
<b>Bearings</b>	#387A Inner #25580 Outer
<b>Hub</b>	8 Lug on 6.5"
<b>Brake</b>	12-1/4" x 3-3/8" Electric 12-1/4" x 3-3/8" Hydraulic Duo Servo* <i>*ABS also available on hydraulic brake</i>
<b>Suspension</b>	Slipper Spring - 2.5" Wide Hanger Kit
<b>Lubrication</b>	Oil Bath (standard) or Grease (optional)

Axle Type	Min.	Max.
<b>Straight (single wheel)</b>	<b>25.37"</b>	<b>31.00"</b>
<b>Straight (dual wheel)</b>	<b>26.00"</b>	<b>31.00"</b>
<b>Straight (optional)</b>	<b>26.00"</b>	<b>49.00"</b>

These axles available on request

Information

Hubs and Axles

Brake Assemblies

Suspensions & Fasteners

Tires & Wheels

Couplers, Jacks & Winches

Hitches & Towing Accessories

Body Components

Boat Trailer Parts

Lights & Electrical

Locks & Cargo Control

Brake Actuating Systems

Switches