

Hubs & Drums for "AL-KO/Hayes" 10K and Larger Axles

These hubs and drums are sold cupped and stubbed, all other parts must be ordered separately. Add "- A" after part # to order complete assembly with parts. Hubs are for oil bath applications only.

Note: Electric brake applications require an armature plate to be purchased separately.

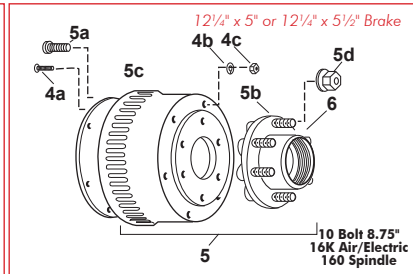
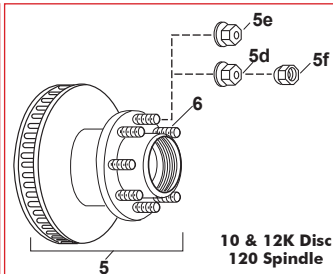
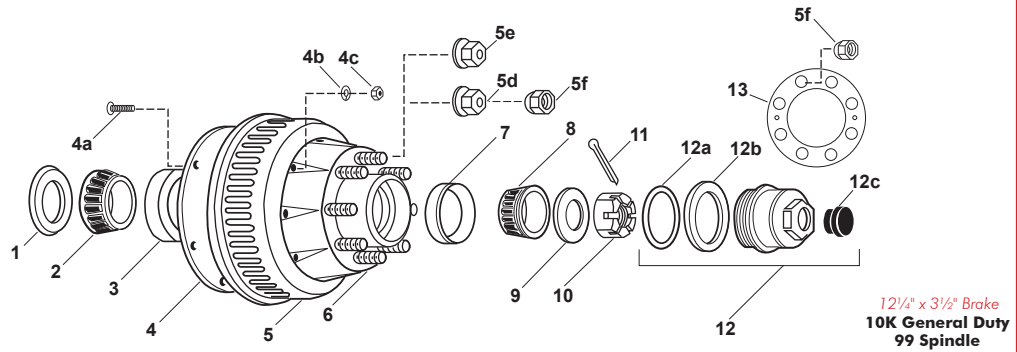

Item #	Description	10K General Duty 99 Spindle	10 & 12K HD 120 Spindle	10 & 12K Disc 120 Spindle	16K Air/Electric 160 Spindle
1	Oil Seal	91030	91023	91023	91023
2	Inner Bearing Cone	28580	JM511946	JM511946	39590
3	Inner Bearing Cup	28521	JM511910	JM511910	39520
4	Armature Plate	H92406	H92406	H92406	H92406
4a	Flat Head Bolt, 1/4" - 20	H9070301	H9070301	H9070301	H9070301
4b	Lock Washer, 1/4"	5128	H90502	H90502	H90502
4c	Hex Nut, 1/4" - 20	H90610	H90610	H90610	H90610
5	Hub & Drum Flat Face	H9080572	-	-	-
5	Hub Drum Coined	H9080567	-	-	-
5a	Hub & Drum Mounting Bolt	-	H90745	-	H90745
5b	Hub Flat Face 5/8" Stud	-	H9089371	H9089421	-
5b	Hub Coined 5/8" Stud	-	H90884	H90814	H90884
5b	Hub Flat Face 3/4" Stud	-	H9089372	H9089425	H9080683
5c	Drum Only	-	H90904	-	H90907
* 5d	5/8" Swiveling Flange Nut	4235	4235	4235	4235
* 5d	3/4" Swiveling Flange Nut	-	4238	4238	4239
** 5e	5/8" Flange Wheel Nut	4233	4233	4233	-
*** 5f	5/8" 90° Cone Wheel Nut	4228	4228	4228	-
6	Wheel Stud - Flat Face	63332	63329	63329	63336
7	Outer Bearing Cup	25520	JM205110	JM205110	JM205110
8	Outer Bearing Cone	25580	JM205149	JM205149	JM205149
9	Spindle Washer	90525	90525	90525	90525
10	Spindle Nut	90623	90623	90623	90623
11	Cotter Pin	91903	91903	91903	91903
12	Oil Cap Assembly	81991	81991	81991	81991
12a	"O" Ring	H92127	H92127	H92127	H92127
12b	Gasket	H9103502	H9103502	H9103502	H9103502
12c	Oil Cap Plug	81989	81989	81989	81989
13	Wheel Clap Ring for 5/8" Studs	133052-01	133052-01	133052-01	-

*Use with flat face wheels

**Use with coined wheels

***Use with wheel clamp ring

Information

Hubs and Axles

Brake Assemblies

Suspensions & Fasteners

Tires & Wheels

Couplers, Jacks & Winches

Hitches & Towing Accessories

Body Components

Boat Trailer Parts

Lights & Electrical

Cargo Control

Brake Actuating Systems

Switches



561-863-2220 • 800-330-1800



561-863-2250 • 888-330-1888



order@expediter.com