

INSTRUCTIONS FOR ACCUTRAC® BRAKE CONTROL

For 2 and 4 brake applications

READ THIS FIRST:

Read and follow all instructions carefully before installing or operating the Brake Control. Keep these instructions with the Brake Control for future reference.

Components of the Brake Control

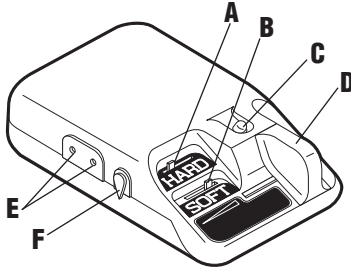

- A. Hard Effort Brake Setting
- B. Soft Effort Brake Setting
- C. Bi-Color Light
- D. Manual Slide Knob
- E. Bracket Mounting Holes
- F. Internal Sensor Adjustment Arm

Important Facts to Remember

1. Do not mount or activate RF generating items (cell phones, two way radios) near (less than 12") the brake control.
2. **CAUTION** Reversing the connection to a breakaway battery on the trailer will destroy the brake control.
3. **CAUTION** Disconnect trailer plug from the tow vehicle prior to testing a breakaway switch, or you may destroy the brake control.
4. The light is:
 - GREEN when trailer is connected.
 - RED when brake pedal or manual is activated and trailer is connected.
 - Flashing RED or OFF when trailer is not connected.
5. The GREEN light draws 10 milliamperes of current from tow vehicle. It would take over 5,000 hours to drain the tow vehicles battery.
6. **WARNING** The Internal Sensor Adjustment is CRITICAL. This adjustment determines the transition point from low effort braking to hard effort braking.
7. **WARNING** The Gross Combined Weight Rating (GCWR) must never exceed the vehicle manufacturers recommendation.
8. This control specifically designed for use with electric trailer brakes.
9. For Technical Assistance and Warranty Information call: 1-888-785-5832 or www.tekonsha.com

Installation Guide

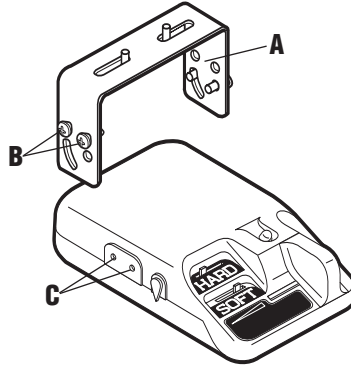

- A. Mounting Bracket
 - B. #6 x 3/8" Screws
 - C. Mounting Holes
1. **CAUTION** Drilling or use of longer screws may damage unit.
 2. Securely mount bracket to a solid surface.
 3. Insert supplied #6 x 3/8" screws on each side into the mounting holes.
 4. Adjust control to desired position and tighten screws until snug.
 5. Once the brake control is securely mounted, point the Internal Sensor Adjustment Arm down to the ground. (See Below)

NOTE: The Brake Control must be mounted from 20 degrees nose down to 70 degrees nose up. (Side Below)

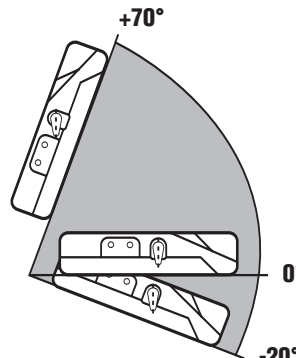

Setting Up the Brake Control

The brake control has independent soft and hard effort brake settings.

- **Soft Effort** – setting for gradual stops, which allows for effective braking without the wheel “hop”.
- **Hard Effort** – setting for hard or panic stop, which is sensed by the Internal Sensor and braking effort is automatically switched over to the Hard Effort Setting.

Setting the Internal Sensor Arm

Once the brake control is securely mounted, the internal sensor adjustment arm must be pointed directly toward the floor of the vehicle. To Fine Tune the sensor, the arm can be moved to change the switching level. This needs to be done after the soft and hard effort levels are set.

NOTE:

1. Always warm the trailer's brakes before setting the power. Warm trailer brakes tend to be more responsive than cold brakes. To warm trailer brakes, drive a short distance (1/4 mile) at 45 MPH with manual lever engaged enough to cause trailer braking at a low level.
2. **WARNING** The power should never be set high enough to cause trailer brakes to lock up. Skidding trailer wheels can cause loss of directional stability of trailer and tow vehicle.
3. The power may need to be adjusted for different load weights and road conditions.
4. Not all trailer brakes will lock up due to various conditions. However, inability to lock up the brakes generally indicates the need for an inspection to determine the cause.
5. When the power is set correctly you should feel unified braking between the trailer and tow vehicle.

Setting the “Hard” Effort Adjustment

1. Connect trailer to tow vehicle.
2. Set HARD adjustment slide to mid-position.
3. Tow trailer at low speed (20-30 mph) on a level, dry and paved surface and apply Manual Slide Knob.
 - ✓ If trailer brakes DO NOT lock up:
 - Increase HARD braking effort by sliding HARD adjustment to the right.
 - ✓ If brakes DO lock up:
 - Decrease HARD braking effort by sliding HARD adjustment to the left.
4. Repeat step (3) until HARD braking effort has been set to a point just below wheel lock up or at a sufficient force as to achieve maximum braking power.

Setting the “Soft” Effort Adjustment

1. After the HARD effort has been set, adjust the SOFT effort adjustment to mid-position.
2. Make a soft stop, such as stopping at a stop sign, etc.
 - ✓ If braking is too aggressive:
 - Decrease SOFT braking effort by sliding SOFT adjustment to the left.
 - ✓ If braking is too light:
 - Increase SOFT braking effort by sliding SOFT adjustment to the right.
3. Repeat step (2) until SOFT braking effort is noticeable but not aggressive.

Continued On Next Page



INSTRUCTIONS FOR ACCUTRAC® BRAKE CONTROL (CONTINUED)

NOTE:

1. If during your attempts to set the SOFT effort control, the braking was too aggressive even with the SOFT effort set to a minimum, the INTERNAL SENSOR ARM is not set correctly, review **Setting the Internal Sensor Arm**.
2. The HARD effort adjustment must be set to allow for proper activation of brakes at quick (hard/fast) stops.
3. Adjustment of SOFT and HARD efforts may be necessary to compensate for changing road conditions, trailer loading, and conditions of trailer brakes.

Fine Tuning the Brake Control

To fine tune the sensor, the arm can be moved to change the switching level.

NOTE:

Only small movements of the internal sensor adjustment arm are needed to cause noticeable differences in the braking response.

- **DELAYED** – move pointer toward *front of vehicle*. This will cause the switching level to be a higher braking effort (HARD effort braking will be controlled by tow vehicle, and the trailer braking will be less than maximum).



- **NORMAL** – recommended starting point before fine tuning, if necessary.



- **AGGRESSIVE** – move pointer toward *rear of vehicle*. This will cause the switching level to be a lower braking effort (gradual stops now become more aggressive).



Troubleshooting Chart

Situation	Probable Cause
No trailer brakes with manual knob activated. Light is GREEN.	- HARD Effort set to minimum, adjust to a higher setting.
No trailer brakes with foot pedal depressed. Light is GREEN.	- SOFT Effort set to minimum, adjust to a higher setting. - Adjustment Arm not set correctly. - RED (stoplight) wire connected incorrectly. - Bad connection on RED wire. - Blown stoplight fuse.
Trailer braking is weak. Light is GREEN / RED.	- SOFT Effort set too low, adjust to a higher setting. - Brake control grounded to interior of vehicle.
Trailer braking is weak or inconsistent. Light is OFF, Flashing RED or DIM.	- Trailer is not connected to vehicle. - Open circuit on brake line. - Ground connection is poor. - No POWER to unit through BLACK wire.
Trailer braking is too strong. Light is GREEN / RED.	- SOFT Effort set too high, adjust to a lower setting. - Adjustment Arm not set correctly.
Trailer brakes locked when connected to vehicle. Light is RED.	- RED (stoplight) wire connected incorrectly. - Breakaway system employed. - BLACK & WHITE wires reversed, control destroyed.
Light is GREEN all the time.	- Short from brake line to ground. - BLACK & WHITE wires reversed, control destroyed.

Appendix A: Trailer Brake Adjustment**

Brakes should be adjusted (1) after the first 200 miles of operation when the brake shoes and drums have "seated," (2) at 3000 mile intervals, (3) or as use and performance requires. The brakes should be adjusted in the following manner:

1. Jack up trailer and secure on adequate capacity jack stands. Follow trailer manufacturers recommendations for lifting and supporting the unit. Check that the wheel and drum rotate freely.
 - ⚠ **WARNING** Do not lift or support trailer on any part of the axle or the suspension system.
2. Remove the adjusting hole cover from the adjusting slot on the bottom of the brake backing plate.
3. With a screwdriver or standard adjusting tool, rotate the starwheel of the adjuster assembly to expand the brake shoes. Adjust the brake shoes out until the pressure of the linings against the drum makes the wheel very difficult to turn.

Note: With drop spindle axles, a modified adjusting tool with about an 80 degree angle should be used.

4. Then rotate the starwheel in the opposite direction until the wheel turns freely with a slight lining drag.
5. Replace the adjusting hole cover and lower the wheel to the ground.
6. Repeat the above procedure on all brakes.

⚠ **WARNING** Never crawl under your trailer unless it is resting on properly placed jack stands.

Follow the trailer manufacturers recommendations for lifting and supporting the unit. Do not lift or place supports on any part of the suspension system.

**Note: Trailer Brake Adjustment procedures courtesy Dexter Axle.

TECHNICAL INFORMATION IS CURRENT AS OF THE PRINTING OF THIS CATALOG. CONTACT TECHNICAL SERVICE FOR PERIODIC UPDATES.