

# HI-POWER 3,000 Acme Jack

## Owner's Instructions (P/N 27265, 27295, 27300)

H&H Engineering "Hi-POWER" Acme Jack is designed to lift up to 3,000 pounds a full 18 inches. Its design also includes a silent shut-off by use of limit switches, a built in leveling device, attached foot plate and an emergency crank. An important part of owning and using HI-Power Jack is being sure it is properly installed and serviced.

### GENERAL SAFETY

- Read and understand the Power Jack installation instructions.
- Always block trailer wheels when using the jack.
- Remove jewelry (watches, rings, etc.).

### BEFORE INSTALLATION

Raise your travel trailer's front end and place blocks or stabilizing jacks under the front "A" frame.

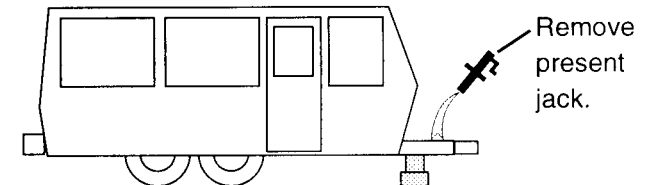

Lower the trailer until it rests securely on stabilizing jacks or blocks. Retract present jack and remove it.

### INSTALLATION

Install Power Jack in hole and secure with, 3 bolts, 3 internal tooth lock-washers (bolt holes are threaded).

Attach the foot plate to HI-POWER Jack with 1/2-20 bolt and 1/2" lockwasher.

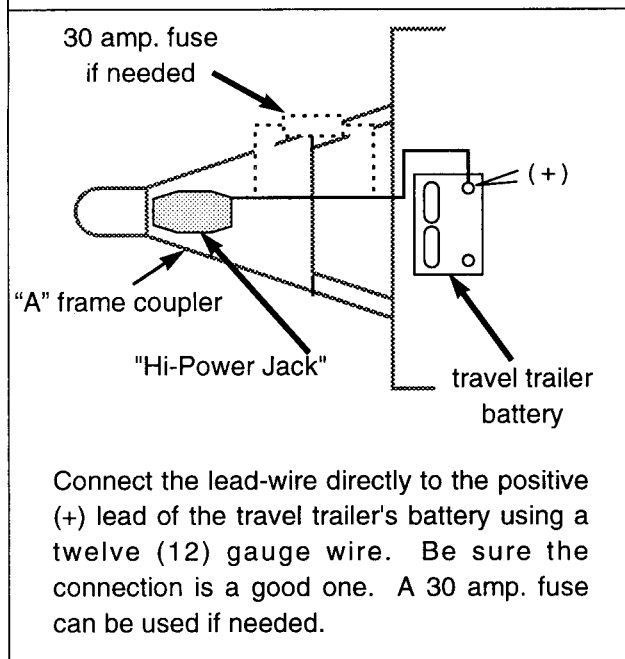

Supplied by customer

### IMPORTANT

To insure a good electrical ground an internal tooth lock-washer must be in place for this bolt.

Make sure powdercoat or paint is removed from "A" frame coupler under washer and that tagged hole is used

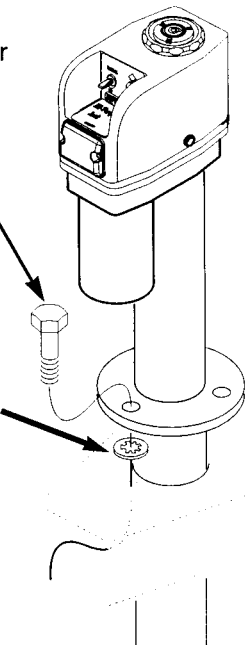

### IMPORTANT NOTICE

If it is necessary to change the position of the powerhead relative to the post and flange (in order to provide clearance between powerhead and LP gas bottle or LP gas cover, or more clearance between the lift gate and powerhead) loosen set screws and rotate head **without** lifting it off coupling. Retighten set screws when head is in desired position. Lifting the unit off the post will make it necessary to resynchronize timing between head and post.

# HI-POWER 3,000 Acme Jack Owner's Instructions

## INITIAL SET UP AND

### HOW TO USE YOUR HI-POWER JACK LEVEL

1. Install your Hi-Power Jack per previous instruction
2. Place a small level inside your RV on a surface you want to level. This might be a counter top or freezer compartment of a refrigerator.

**NOTE:** It will be necessary to move this level to check side to side and front to back condition.

3. Checking the "inside level", level your trailer from side to side with stabilizing jacks or board under wheels.

4. Checking the "inside level", level your trailer front to back using your HI-POWER JACK.

5. Carefully adjust the 3 stainless steel screws on the ring that surrounds the built in bulls-eye level (see picture) until the air-bubble is inside the middle circle mark, it will then be leveled.

In the future, you can do all your leveling by using your HI-POWER JACK built in level.

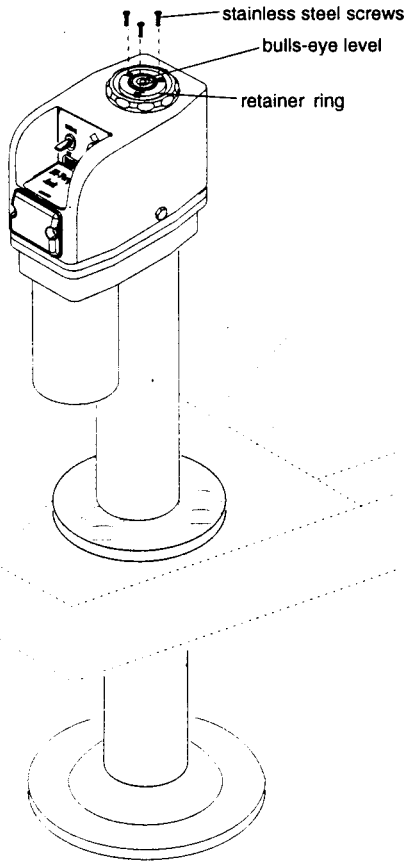

## OPERATION (ELECTRIC)

-REMEMBER TO KEEP HANDS AND FEET FROM UNDER THE FOOT PLATE WHEN USING POWER JACK.

-WHEN THE HI-POWER JACK REACHES THE END OF IT'S TRAVEL(EITHER RAISING OR LOWERING) INTERNAL LIMIT SWITCHES AUTOMATICALLY SHUT MOTOR OFF.

-DOLLY WHEELS ARE NOT RECOMMENDED.



### WARNING

Avoid the risk of injury to yourself and others:

- Use the jack for lifting the travel trailer only.
- Never get beneath the travel trailer when it is supported by the jack.
- Support the vehicle with the appropriate means.

The "night-light" is controlled by this toggle switch

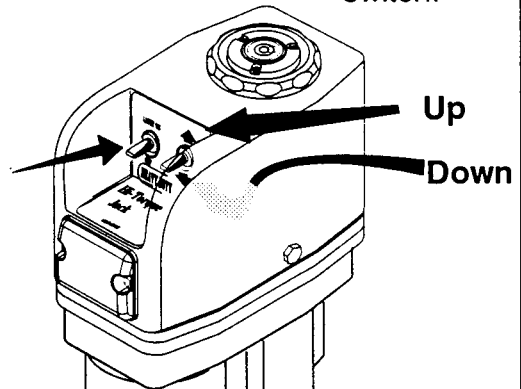

REV: 4/25/01

P/N 27326

2 of 5

**h** H&H ENGINEERING

DIVISION OF BARKER MFG. CO. / 730 E. MICHIGAN AVE. / P.O. BOX 460 / BATTLE CREEK MI 49016 / (616) 965-2371

© Copyright H&H Engineering 1989

# HI-POWER 3,000 Acme Jack Owner's Instructions

## OPERATION (MANUAL)

If an electrical failure should ever occur the emergency handle may be inserted into the jack post and the jack can be raised or lowered. (Access can be obtained by twisting level cap off.)

If powerhead is removed crank can still be used to raise and lower jack.

### CAUTION!!

If powerhead is removed it must be synchronized with the jackpost

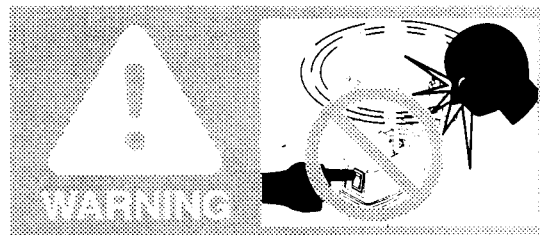
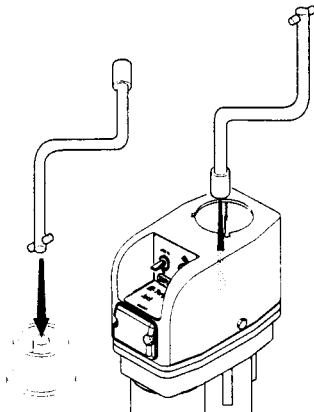

### WARNING Crank Handle

Do not use toggle switch with crank handle in place. Breaking this rule will cause serious injury.

REMEMBER TO KEEP HANDS AND FEET OUT FROM UNDER THE FOOT PLATE WHEN USING THE POWER JACK.

## SYNCHRONIZATION INSTRUCTIONS

### Powerhead must be synchronized with the jack post

1. Use the crank to fully retract post.
2. Crank jackpost one turn in opposite direction.
3. Ground powerhead to jackpost or trailer frame
4. Toggle switch down as if lowering the trailer or retracting the post. Continue to hold switch down until motor stops running (as if jackpost is retracted all the way).
5. Install powerhead and tighten (3) set screws.



**H&H ENGINEERING**

DIVISION OF BARKER MFG. CO. / 730 E. MICHIGAN AVE. / P.O. BOX 460 / BATTLE CREEK MI 49016 / (616) 965-2371

© Copyright H&H Engineering 1989

REV. 4/25/01

P/N 27326

3 of 5

# HI-POWER 3,000 Acme Jack Owner's Instructions

## Parts:

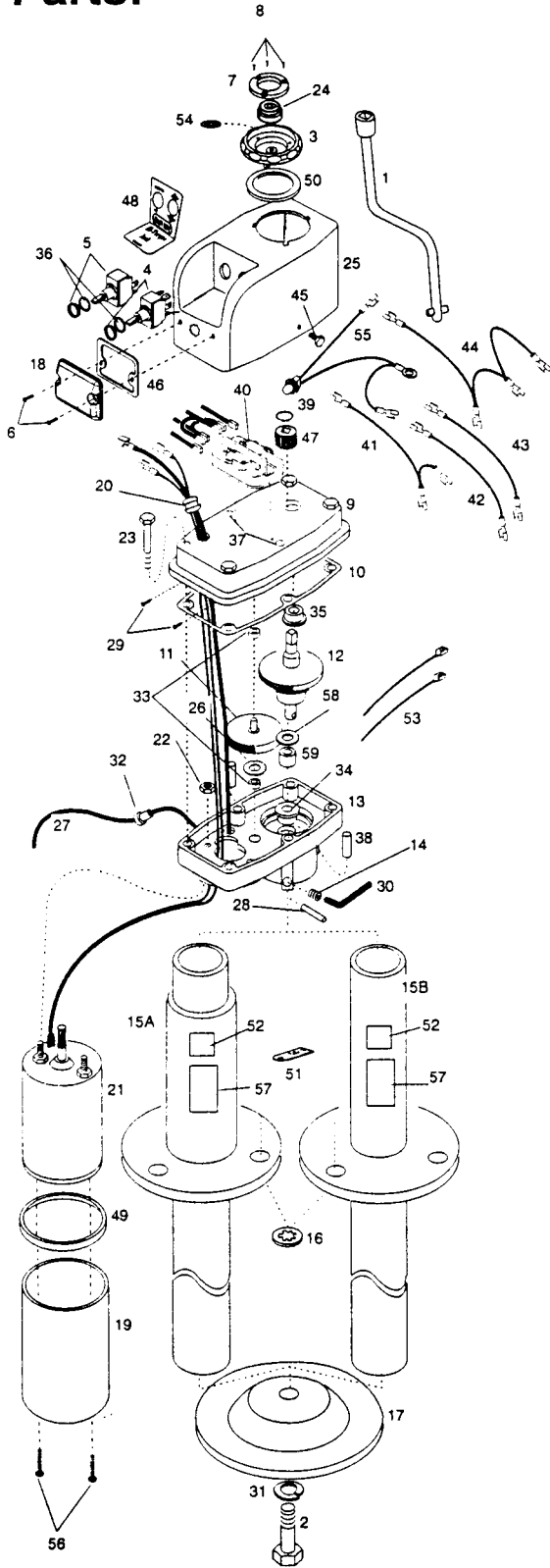

Item	Part No.	Req'd	Description
3	27268	1	CAP, MACHINED-BLACK
3	27341	1	CAP, MACHINED-WHITE
4	736-0005	1	ACTUATOR TOGGLE SWITCH AND NUT
5	736-0004	1	LAMP TOGGLE SWITCH AND NUT
6	606-5001	2	#10 X 1/2 PHILLIPS HEAD SCREW
7	27269	1	LEVEL RETAINER-BLACK
7	27343	1	LEVEL RETAINER-WHITE
8	606-0011	3	#6-32 X 5/8 TYPE "F" SCREW
9	27247	1	UPPER HOUSING
10	17422	1	GASKET
11	22012	1	DRIVE GEAR ASSEMBLY
12	27248	1	OUTPUT GEAR ASSEMBLY
13	25697	1	LOWER HOUSING (WHITE)
13	23674	1	LOWER HOUSING (BLACK)
14	608-0006	3	5/16-18 X 1/2" SET SCREW
15A	27313	1	POST ASS'Y. (BLACK-2 1/4" OD)
15B	27335	1	POST ASS'Y. (BLACK-2" OD)
15A	27527	1	POST ASS'Y. (WHITE-2 1/4" OD)
16	619-0003	3	INTERNAL TOOTH LOCK WASHER
17	21349	1	FOOT PLATE (BLACK)
17	12752	1	FOOT PLATE (SILVER, WHITE)
18	27262	1	LENS
19	27276	1	MOTOR SLEEVE (BLACK)
19	27344	1	MOTOR SLEEVE (WHITE)
20	26236	1	RUBBER GROMMET
21	17414	1	ELECTRIC MOTOR
22	611-2100	2	HEX LOCK NUT
23	605-0012	4	SCREW
24	27272	1	CIRCULAR LEVEL
25	27338	1	COVER (WHITE)
25	27259	1	COVER (BLACK)
26	80208	1	WASHER, SPACER
27	27251	1	GREY WIRE ASSEMBLY
28	623-1216	1	GROOVE PIN
29	606-0009	2	#10 X 3/8 SCREW (LIMIT SWITCH)
30	636-0000	1	HEX KEY
31	618-1002	1	LOCKWASHER (1/2")
32	80504	1	SNAP BUSHING
33	80501	2	BUSHING
34	645-0024	1	FLANGE BUSHING
35	641-0009	1	BUSHING
36	635-0015	1	"O"-RING TOGGLE SWITCH SEAL
37	16434	2	HOLE PLUG
38	621-0004	2	1/8" DIA X 3/4 DOWEL
39	634-0023	1	RETAINER RING
40	27512	1	LIMIT SWITCH ASS'Y
41	27257	1	BLACK WIRE ASSEMBLY
42	27256	1	WHITE WIRE ASSEMBLY
43	27254	1	BLUE WIRE ASSEMBLY
44	27252	1	GREEN WIRE ASSEMBLY
45	606-0008	2	#10-16 X 3/4 TEK SCREW (BLACK)
45	606-0010	2	#10-16 X 3/4 TEK SCREW ZINC PLATED
46	27263	1	LENS GASKET
47	27277	1	POT/REED DRIVE GEAR
48	27264	1	COVER LABEL
49	27274	1	MOTOR SEAL
50	27273	1	CAP GASKET
51	26351	1	I.D. TAG (55:1)
52	24047	1	WARNING LABEL
53	17892	2	CABLE TIE- GREY
53	16392	2	CABLE TIE- BLACK
54	620-0000	1	WAVE SPRING
55	27253	1	LAMP WIRE ASS'Y
56	603-5017	2	#10-32 x 5/8" PHILLIPS SCREW (BLACK)
56	603-5011	2	#10-32 x 5/8" PHILLIPS SCREW (SILVER)
57	12393	1	SYNCHRONIZE LABEL
58	14459	1	THRUST WASHER
59	14489	1	1/2 X 5/8 X 3/4 BEARING

Item	Part No.	Req'd	Description
1	21047	1	CRANK
2	600-0011	1	HEX BOLT (1/2-20 X 3/4")

# HI-POWER 3,000 Acme Jack Owner's Instructions

## MAINTENANCE

Once a year, the powerhead should be removed and a liberal amount of grease (preferably a grease with high melting point) applied directly to the coupling on which the drive pin rests. DO NOT POUR OIL into top of jack post.

Once a year, the housing cover should be removed and the gears inspected for proper lubrication. Remove 4 screws and tap around edges of housing to free the cover--DO NOT insert screwdriver blade-- this may damage mating surfaces. Before replacing cover, clean mating surfaces. If lubrication is needed, use Mobilith 460 grease or equivalent.

### Schematic Wiring Diagram

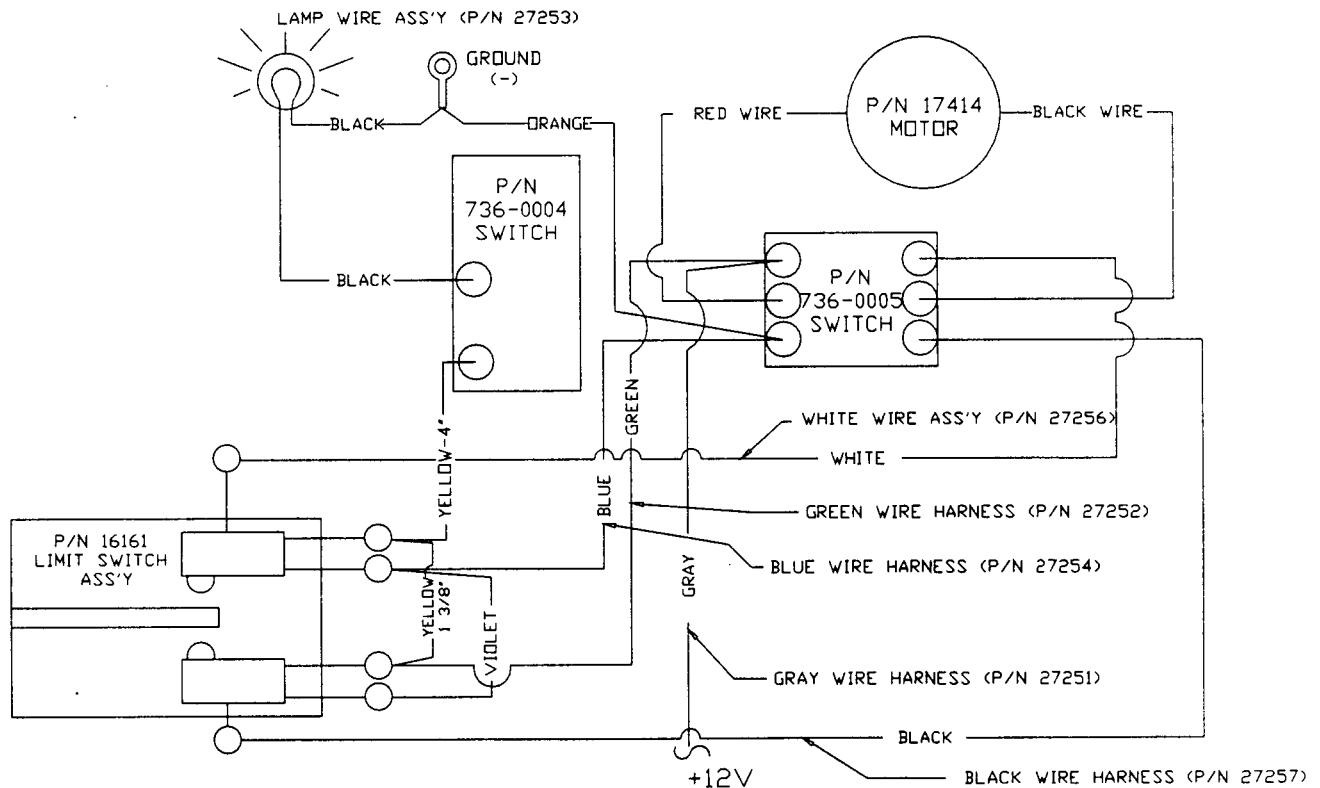

© Copyright H&H Engineering 1989

REV. 4/25/01

P/N 27326

5 OF 5

**h&h** H&H ENGINEERING

DIVISION OF BARKER MFG. CO. / 730 E. MICHIGAN AVE. / P.O. BOX 460 / BATTLE CREEK MI 49016 / (616) 965-2371