

Power Jack Owner's Instructions

H&H Engineering Power Jack is designed to lift up to 2,000 pounds a full 18 inches. Its design also includes a special clutch (torque limiter) that prevents damage to the jack, and attached foot plate. An important part of owning and using Power Jack is being sure it is properly installed and serviced.

GENERAL SAFETY

- Read and understand the Power Jack installation instructions.
- Always block trailer wheels when using the jack.
- Remove jewelry (watches, rings, etc.).
- Prolonged operation of the torque limiter is not recommended.

BEFORE INSTALLATION

Raise your travel trailer's front end and place blocks or stabilizing jacks under the front "A" frame.

Lower the trailer until it rests securely on stabilizing jacks or blocks. Retract present jack and remove it.

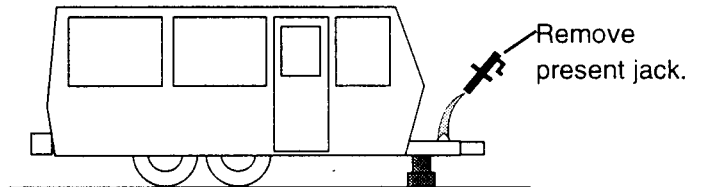

INSTALLATION

Install Power Jack in hole and secure with, 3 bolts, 3 internal tooth lock-washers (bolt holes are threaded).

Attach the foot plate to Power Jack with 1/2-20 bolt and 1/2" lockwasher.

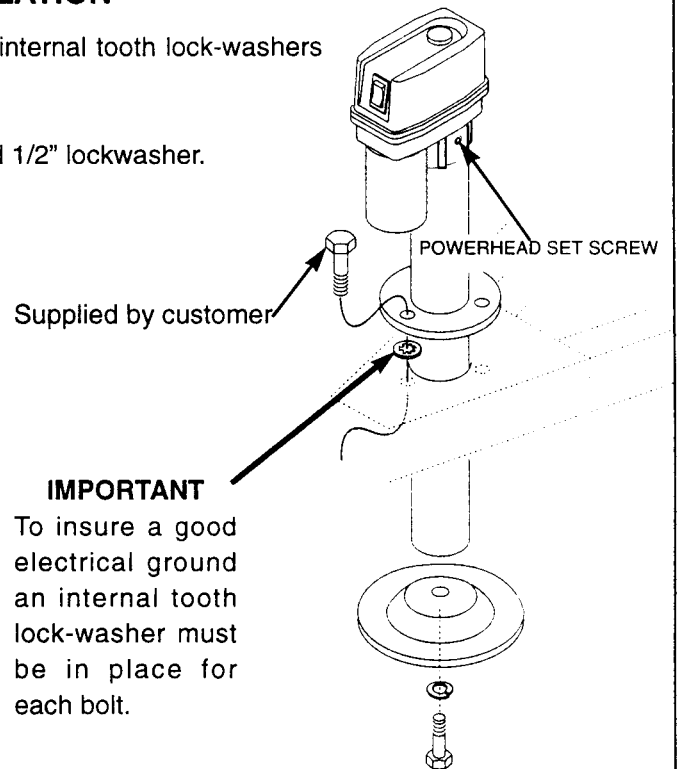
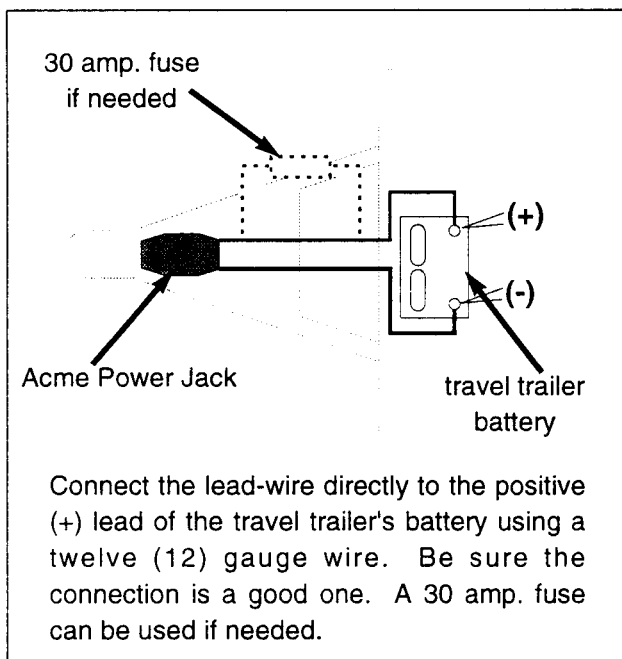

IMPORTANT NOTICE

Powerhead may be repositioned and rotated to eliminate interference with LP gas cylinder shroud.

- Just loosen set screws on powerhead collar, position head in desired location and retighten set screws.



Power Jack Owner's Instructions

OPERATION (ELECTRIC)

REMEMBER TO KEEP HANDS AND FEET FROM UNDER THE FOOT PLATE WHEN USING POWER JACK.

When the H&H Power Jack reaches the end of its travel (either raising or lowering) a built in torque limiter goes into operation with a clicking noise.

This torque limiter permits the final drive gear to slip and thus protects the unit. PROLONGED OPERATION OF THE TORQUE LIMITER IS NOT RECOMMENDED.

DOLLY WHEELS ARE NOT RECOMMENDED.

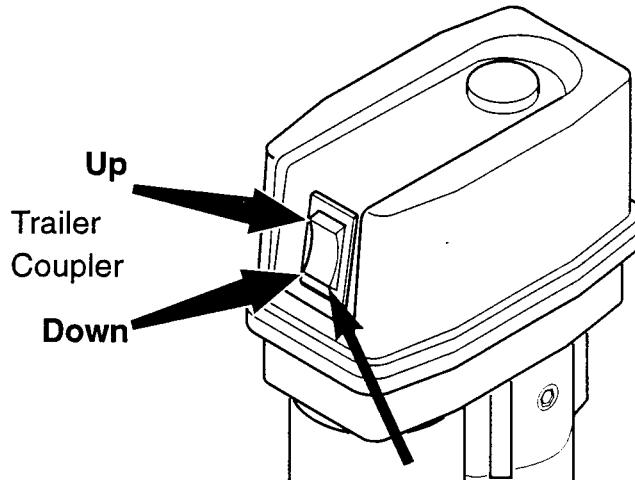

Use the rocker switch to raise or lower the jack.

WARNING

Avoid the risk of injury to yourself and others:

- Use the jack for lifting the travel trailer only.
- Never get beneath the travel trailer when it is supported by the jack.
- Support the vehicle with the appropriate means.

OPERATION (MANUAL)

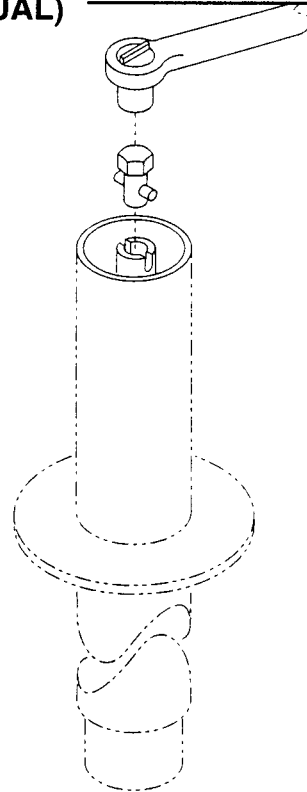

If an electrical failure should ever occur remove the powerhead by loosening the 3 allen set screws holding it to the jackpost. Couple the crank adapter to a 5/8" hex socket, insert into the jackpost and the jack can be raised and lowered.

REMEMBER TO KEEP HANDS AND FEET OUT FROM UNDER THE FOOT PLATE WHEN USING THE POWER JACK.

Power Jack Owner's Instructions

Parts

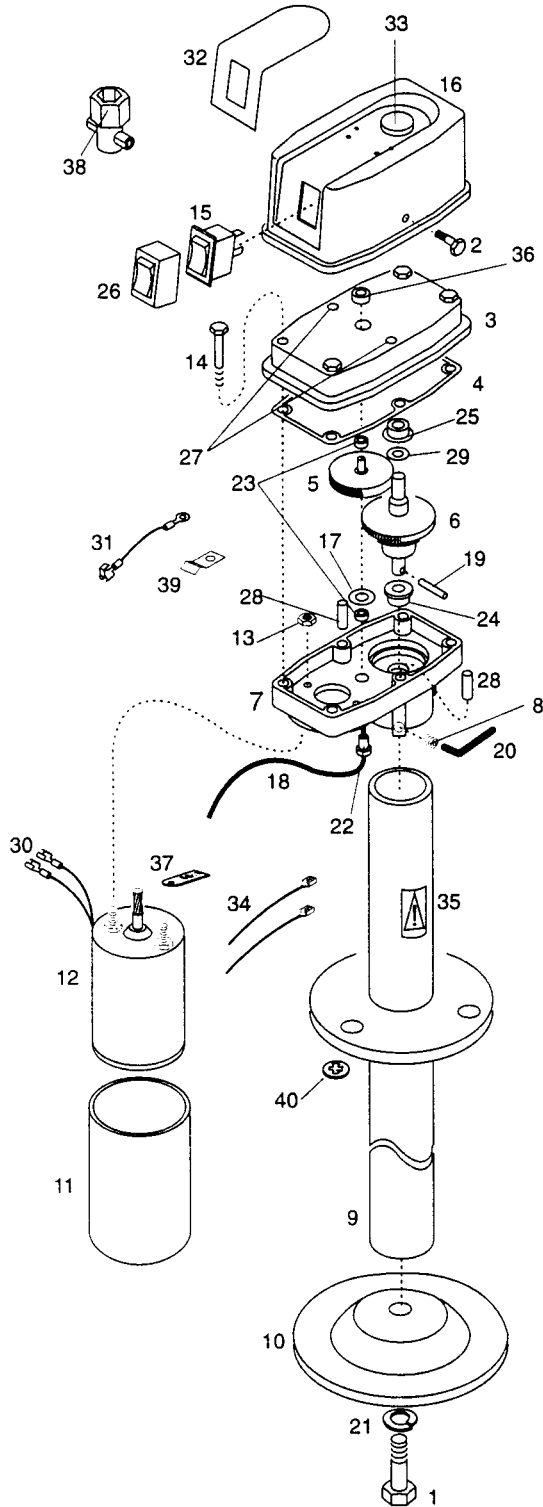

Item	Part No.	Req'd	Description
1	600-0011	1	BOLT (1/2-20 X 3/4")
2	606-0000	2	SCREW SILVER
2	606-0001	2	SCREW BLACK
3	17445	1	UPPER HOUSING
4	17422	1	GASKET
5	26307	1	DRIVE GEAR ASSEMBLY
6	23653	1	TORQUE LIMITER ASSEMBLY
7	25399	1	LOWER HOUSING (BLACK)
7	24937	1	LOWER HOUSING (WHITE)
8	608-0006	3	SET SCREW
9	24869	1	POST BODY ASS'Y. (BLACK) (2" OD)
9	24940	1	POST BODY ASS'Y. (WHITE) (2" OD)
10	21349	1	FOOT PLATE (BLACK)
10	12752	1	FOOT PLATE (WHITE)
11	18843	1	MOTOR SLEEVE (BLACK)
11	24941	1	MOTOR SLEEVE (WHITE)
12	24901	1	ELECTRIC MOTOR
13	611-2100	2	HEX LOCK NUT
14	605-0012	4	SCREW
15	738-0007	1	ROCKER SWITCH
16	17425	1	COVER (BLACK)
16	24942	1	COVER (WHITE)
17	80208	1	WASHER, SPACER
18	23212	1	GREY WIRE ASSEMBLY
19	623-1216	1	GROVE PIN
20	636-0000	1	HEX KEY
21	618-1002	1	LOCKWASHER (1/2")
22	80504	1	SNAP BUSHING
23	80501	2	BUSHING
24	645-0024	1	FLANGE BUSHING
25	10055	1	FLANGE BUSHING
26	22414	1	SWITCH SEAL
27	16434	2	HOLE PLUG
28	621-0004	2	1/8" DIA X 3/4 DOWEL
29	617-1011	1	THRUST WASHER
30	81758	2	12 GA FEMALE TERMINAL
31	17801	1	GROUND WIRE ASSEMBLY
32	24871	1	COVER LABEL (BLACK)
32	24982	1	COVER LABEL (WHITE)
33	24872	1	HOLE PLUG (BLACK)
33	24939	1	HOLE PLUG (WHITE)
34	16392	2	CABLE TIE (BLACK)
34	17892	2	CABLE TIE (GREY)
35	24047	1	WARNING LABEL
36	26236	1	RUBBER GROMMET
37	26351	1	I.D. TAG 55:1
38	25902	1	ADAPTER ASS'Y
39	17808	1	WIRE CLAMP
40	619-0003	3	LOCKWASHER

Power Jack Owner's Instructions

MAINTENANCE

Once a year, the powerhead should be removed and a liberal amount of grease (preferably a grease with high melting point) applied directly to the coupling on which the drive pin rests. DO NOT POUR OIL into top of jack post.

Once a year, the housing cover should be removed and the gears inspected for proper lubrication. Remove 4 screws and tap around edges of housing to free the cover--DO NOT insert screwdriver blade-- this may damage mating surfaces. Before replacing cover, clean mating surfaces. If lubrication is needed, use a Lithium based gear grease.

Pictorial Wiring Diagram

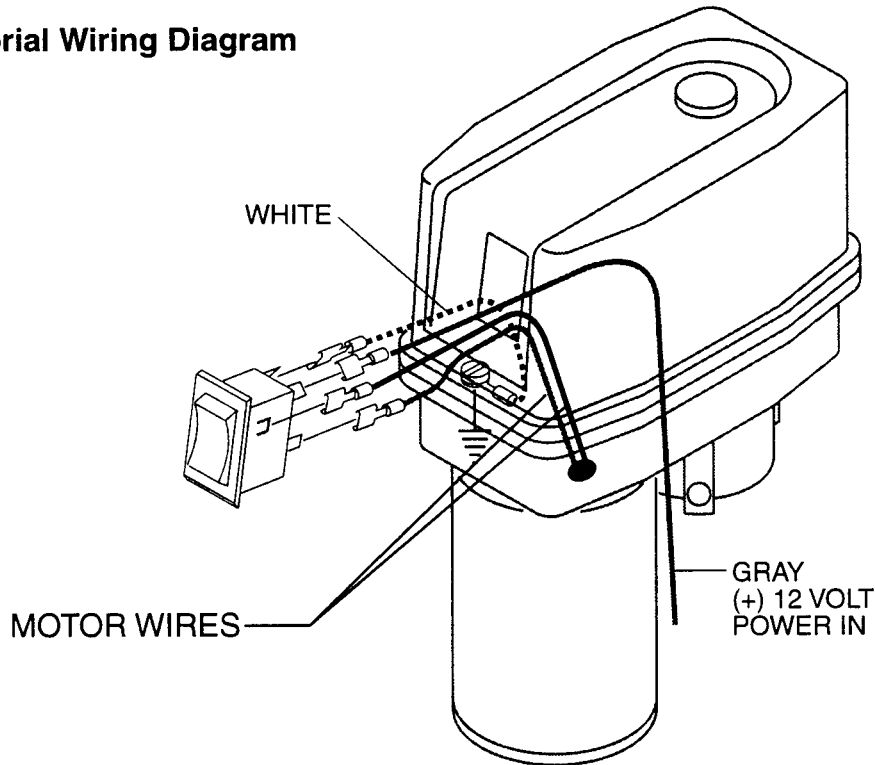

Schematic Wiring Diagram

