

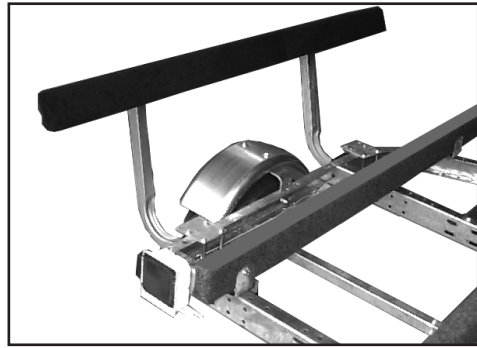

## 60" BUNK GUIDES

Assembly Instructions

Stk # 86124



Thank you for purchasing the Long Run Bunk Guides. Please review the following instructions before starting the assembly. With proper care, the Bunk Guides will give you years of service.

### Tools Required:

9/16" Deep Socket, 9/16" Wrench,  
Phillips Head Screw Driver

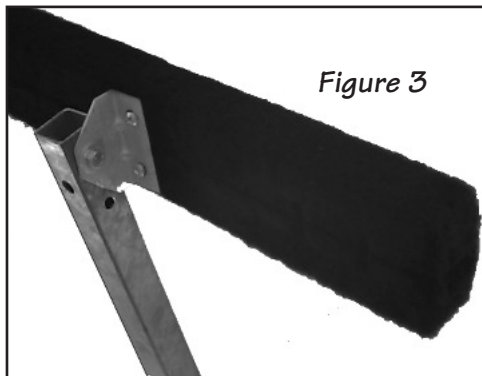
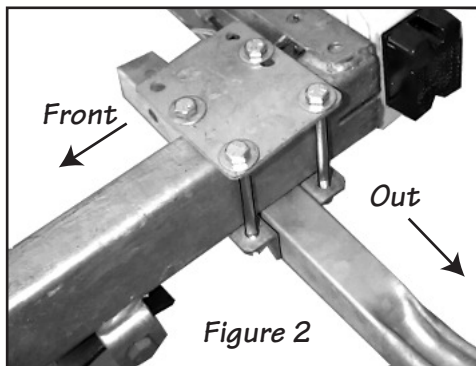
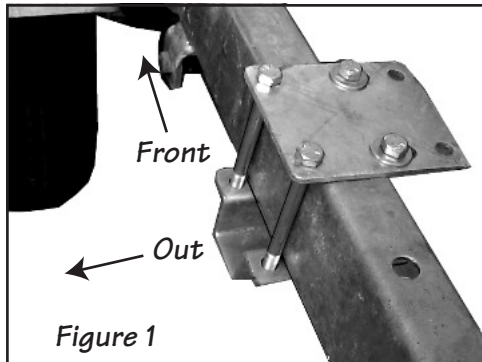

### Parts List

Description	Qty
60" Carpeted Bunks	2
34" x 1-1/2" sq. Support Tube	4
Upper Mounting Plate	4
Lower Mounting Bracket	4
3/8"x 5" Hex Head Bolt	16
3/8"x2.5" Hex Head Bolt	4
3/8" Hex Nyloc Nut	20
3/8" Flat Washer	40
Plastic End Cap	4
Hex Head Screws	8
Swivel Mount Brackets	4

1. Before assembling the mounting hardware as shown in figure 1, decide where you will want the bunk guides placed on your trailer. Mounting brackets should be placed 3' to 4' apart to provide support for the 60" bunks.

2. Using 4 - 3/8" x 5" hex head bolts, 8 flat washers and 4 nyloc nuts, for each, attach the guide support mounts onto your trailer frame, as shown in figure 1. Use the holes that will keep the bolts closest to the frame tube. Finger tighten at this time. Repeat for support mount.

3. Slide the guide support tube into each assembly as shown in figure 2.

4. Use a 3/8" x 2-1/2" hex head bolt and nyloc nut to attach a swivel bracket to each support tube as shown in fig 3. Top mounting hole should be used. Swivel bracket should be mounted on the "outside" of each support mount. Tighten bolt to allow swivel bracket to stay in place when moved.

5. Center the bunks on the support brackets and attach the bunks using 2 phillips head screws at each swivel bracket (Fig 3).

6. Adjust the guide tubes for the proper distance on each side. Tighten support mount bolts at this time. Adjust the bunks for the proper angle and tighten the bolts.

Instructions # 15345

**TIE DOWN ENGINEERING • 5901 Wheaton Drive • Atlanta GA, 30336**  
**www.tiedown.com • (404) 344-0000 • FAX (404) 349-0401**

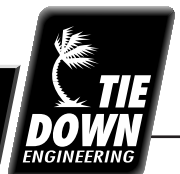

042203,101