



Turbo Lube Hub Owners Manual



TIE DOWN ENGINEERING, Inc.

5901 Wheaton Drive, Atlanta, GA 30336

www.tiedown.com

(404) 344-0000 • Fax (404) 349-0401

© 2007 TIE DOWN ENGINEERING, INC. ALL RIGHTS RESERVED



Turbo Lube Hubs Oil Bath Lubrication

Simple is best. Especially when it comes to wheel bearing maintenance. That's why Tie Down has developed Turbo Lube, the hub bearing lubrication system that provides continuous protection.

Turbo Lube oil bath lubricating system rotates individual roller bearings over four times through oil for each wheel revolution keeping your hub and bearings cooler, reducing wear and friction, and actually increasing tow vehicle mileage. The unique see through threaded oil cap assures a leak proof seal and let's you know if your bearings have adequate lubrication for the next long run.

The Turbo Lube system provides extended bearing life by thoroughly distributing oil and eliminates the need to disassemble the hubs and repack the wheel bearings. Simply put, that means peace of mind for you.

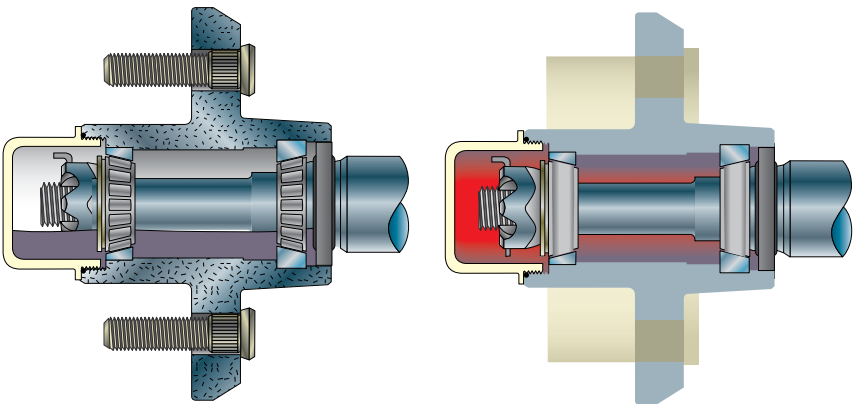

As your speed increases, the oil inside the Turbo Lube Hub uses the centrifugal force to completely lubricate all the bearings.

Turbo Lube Hub Caps



“Hub Fill”

If you have this model follow the instructions for the “Top Fill” on pages 4 & 5.



“Top Fill”

If you have this model follow the instructions on pages 4 & 5



“Front Fill”

If you have this model follow the instructions on pages 6 & 7

Turbo Lube Hub (Top Fill) Bearing Lubrication/Maintenance

1. Remove oil filling plug from Turbo Lube Cap. Add oil into the Turbo Lube Hub.
2. Add oil (2.5 - 3 oz.) until oil level is appropriately half full on the see through oil cap (up to MAX FILL line). Some time should be given to allow oil to pass through the bearings and level off. **DO NOT OVER FILL.**
3. Replace oil filling plug.
4. Check oil level. Add oil if necessary (repeating step 1,2 & 3) to maximum fill level on the see-through oil cap. **DO NOT OVER FILL.**
5. Mount tire/wheel.
6. Check oil level in the Turbo Lube Hub before each trip. Add oil if required to "MAX FILL" line on cap.

NOTE: It is normal for the oil to change color after a few miles of use. Even a small amount of moisture condensation can cause the oil to turn milky.

Materials needed: 50w Oil (min.) 90 Weight Gear (max.) Oil Recommend. 50w synthetic is preferred, any quality brand oil is OK.

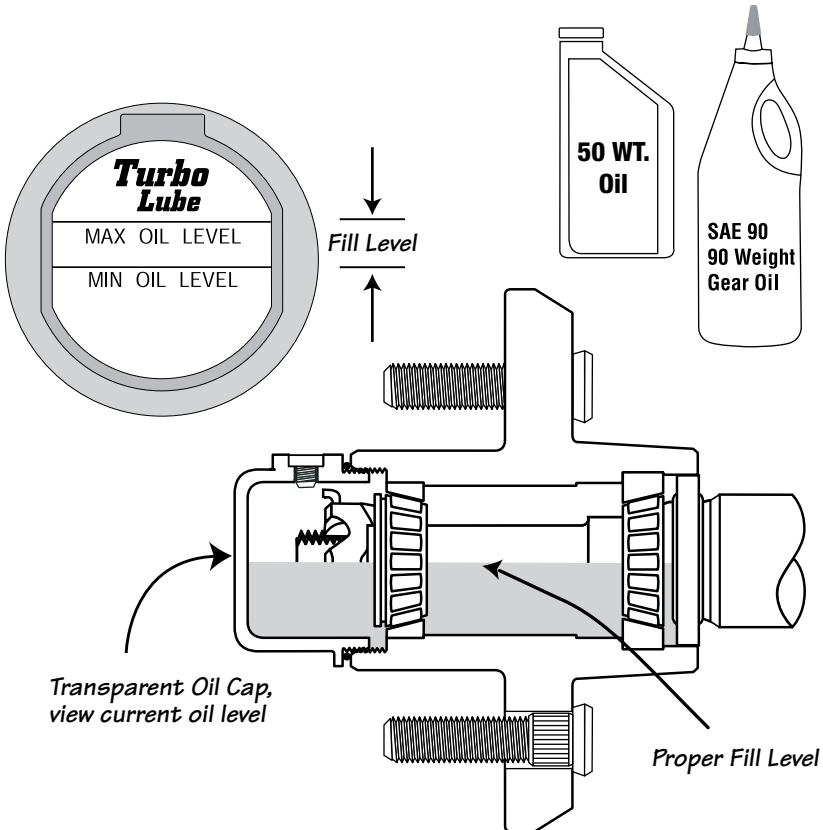

Turbo Lube Hub (Top Fill) Installation/Replacement Instructions

1. Remove wheel from hub.
2. Remove hub dust cap, cotter key or flange washer, spindle nut and thrust washer.
3. Remove old hub from spindle.
4. Wipe spindle clean, check for any noticeable wear or rust.
NOTE: Excessively worn seal surface can allow moisture to enter the hub
5. Assemble new hub. Set bearings as shown, if not already pre-assembled.
6. Place a thin coating of oil or grease on spindle surface. Mount Turbo Lube Hub.
7. Tighten the spindle nut with a 1/2 inch torque wrench to approximately 40 ft. lbs. Turn wheel in both directions to confirm wheel turns freely.
8. Turn back spindle nut 1/6 turn maximum to the nearest cotter key or flange washer locking position. Wheel should turn smoothly with no end play or wobble.
9. Place the Turbo Lube O-ring over the threaded portion of the Turbo cap.
10. Install oil cap, turn clockwise, snug by hand and then turn 1/4 additional turn. Do not over tighten. See back diagram.

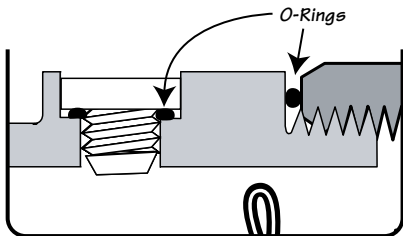
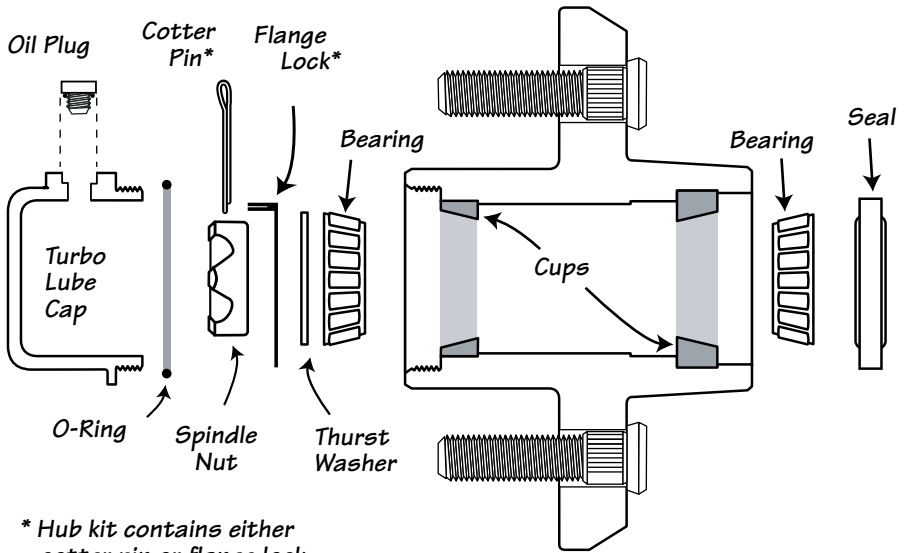

Hand tighten cap until snug. Use wrench to turn an addition 1/4 turn. Check to make sure that the O-rings are seated properly. Be careful not to over tighten. Check oil level, fill if necessary. Tighten oil plug cap.

Turbo Lube Hub (Front Fill) Bearing Lubrication/Maintenance

1. Remove oil filling plug from Turbo Lube Cap. Add oil into the Turbo Lube Hub.
2. Add oil until oil level is just below the filler hole. Some time should be given to allow oil to pass through the bearings and level off.
3. Replace oil filling plug.
4. Check oil level. Add oil if necessary (repeating step 1,2 & 3).
5. Mount tire/wheel.
6. Check oil level in the Turbo Lube Hub before each trip. Add oil if required to the bottom of the filler hole on cap.

NOTE: It is normal for the oil to change color after a few miles of use. Even a small amount of moisture condensation can cause the oil to turn milky.

Materials needed: 50w Oil (min.) 90 Weight Gear (max.) Oil Recommend. 50w synthetic is preferred, any quality brand oil is OK.

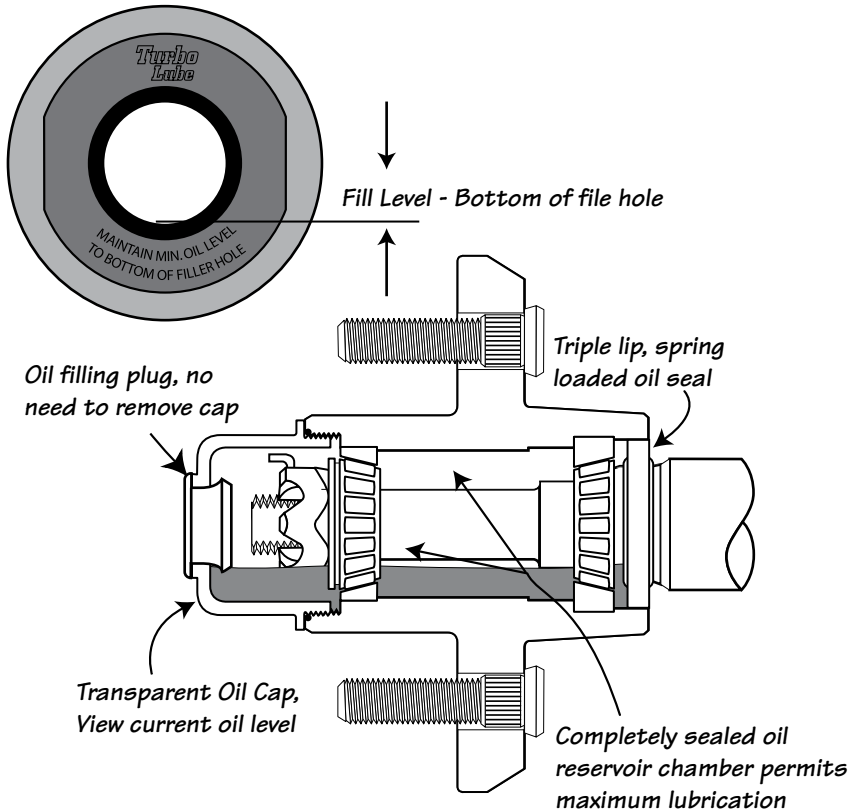

Turbo Lube Hub (Front Fill) Installation/Replacement Instructions

1. Remove wheel from hub.
2. Remove hub dust cap, cotter key or flange washer, spindle nut and thrust washer.
3. Remove old hub from spindle.
4. Assemble new hub. Set bearings as shown, if not already preassembled.
5. Wipe spindle clean, check for any noticeable wear or rust.
6. Place a thin coating of oil or grease on spindle surface.
7. Mount Turbo Lube Hub.
8. Tighten the spindle nut with a 1/2 inch torque wrench to approximately 40 ft. lbs. Turn wheel in both directions to confirm wheel turns freely.
9. Turn back spindle nut 1/6 turn maximum to the nearest cotter key or flange washer locking position. Wheel should turn smoothly with no end play or wobble.
10. Install oil cap, turn clockwise, snug by hand and then turn 1/4 additional turn. Do not over tighten. See back diagram.

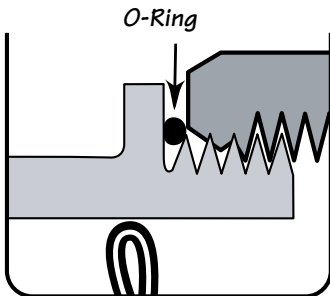
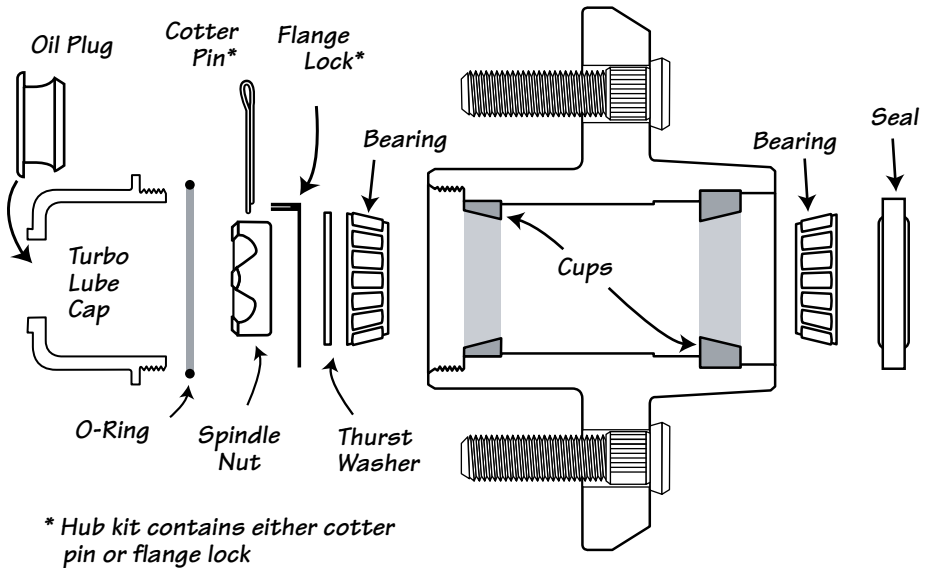

Hand tighten cap until snug. Use wrench to turn an addition 1/4 turn. Check to make sure the O-ring is seated properly. Be careful not to over tighten. Check oil level, fill if necessary. Tighten oil plug cap.

Stainless Steel Wear Sleeve Instructions

NOTE: If you have stainless steel wear sleeves, use the following instructions:

When installing turbo lube hubs on an existing axle that has stainless steel wear sleeves, apply a high temperature silicone sealant like "RTV" (NOT INCLUDED) to the inside and outside area where the seal meets the spindle surface. Allow sealant to fully "CURE" before assembly. This must be done to prevent potential oil leakage under the wear sleeve.

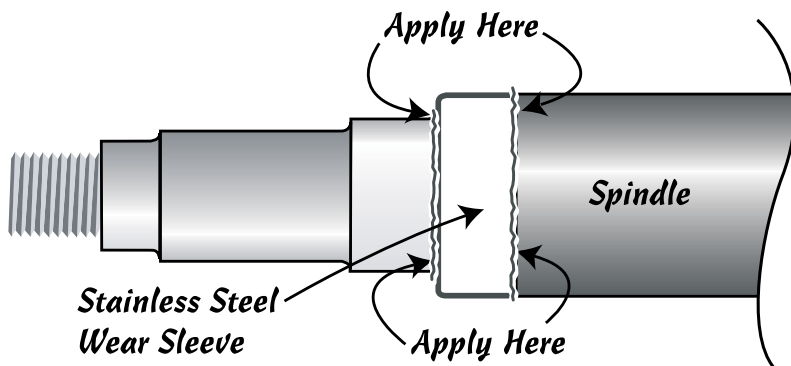

TIE DOWN ENGINEERING, Inc.

5901 Wheaton Drive, Atlanta, GA 30336

www.tiedown.com

(404) 344-0000 • Fax (404) 349-0401

© 2007 TIE DOWN ENGINEERING, INC. ALL RIGHTS RESERVED