

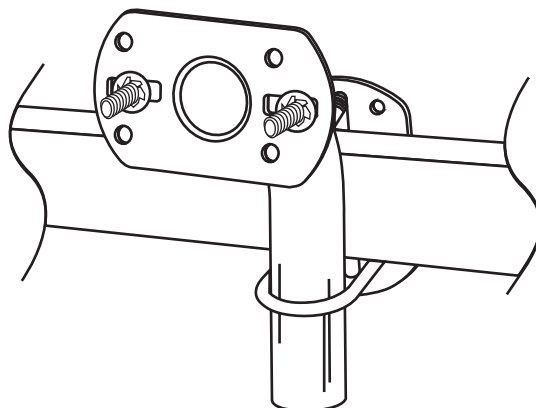

best in the  
**LongRun**



## High Mount Spare Tire Carrier Instructions Part #86101

### Tools Required:

3/4" Wrench or 3/4" Socket

- Using the spare tire carrier and spare tire as a guide, determine a suitable mounting location on trailer frame.
- Push the 1/2"x 6" bolt through the tube and position on top of the trailer frame.
- Place the mounting plate against the inside of the frame with the 1/2" bolt going through the top oval hole.
- The mounting plate will accommodate several size frames by using the various hole patterns. The mounting plate can even be rotated 180° to provide a tight fit. **NOTE: see below diagram for 2x3 and 3x4 frame tubes.**
- Slide U-bolt around the tire carrier tube below the frame and through the bottom holes in the mounting tube.
- Check position of the tire mount for proper clearance with the spare tire before tightening bolts.
- Mount spare tire with 1/2" bolts, washers and lug nuts provided.
- Place the carriage bolts provided for mounting the spare tire in the rectangular holes on the mounting plate. Bolt heads should be on the back side of the tire carrier. Secure bolts with "star" washers.

### Parts List:

Part #	Description	Qty.
48052	Spare Tire Carrier	1
48053	Tire Carrier Mounting Plate	1
10645	Nyloc Nut 1/2"	3
10019	Washer 1/2"	1
10017	Washers 3/8"	2
10918	Carriage Bolt 1/2"x1-3/4"	2
10951	Hex Head Bolt 1/2"x6-1/2"	1
83360z	Ubolt 3/8"x 1.88"x 6"	1
10951	Hex Head Bolt 1/2"x1-3/4"	2
10640	Bolt Retainer "Star Washer"	2

### Rear Mounting Plate Top

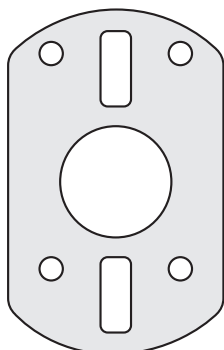

Position for  
2"x 3" Tubes

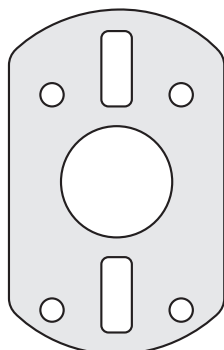

Position for  
3"x 4" Tubes

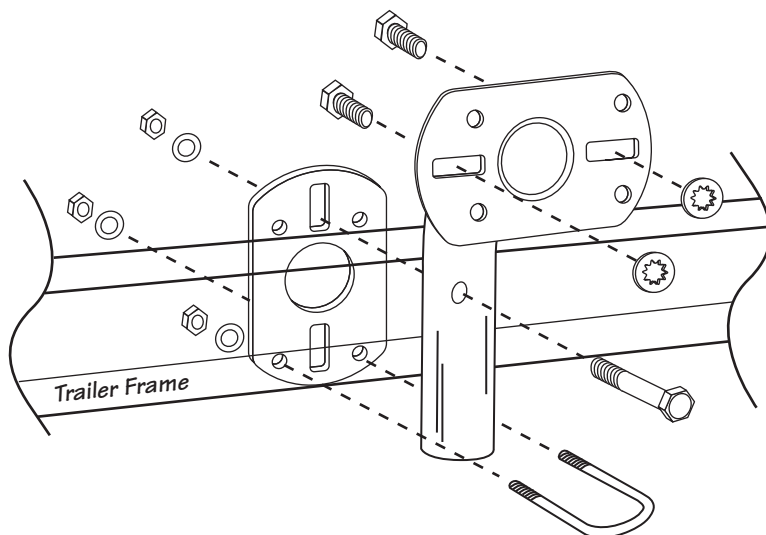

Instruction Sheet #08073

**TIE DOWN ENGINEERING • 5901 Wheaton Drive • Atlanta GA, 30336**  
**www.tiedown.com • (404) 344-0000 • FAX (404) 349-0401**



081007.A804