

Tote N Tow

Assembly Instructions

Stk # 86171

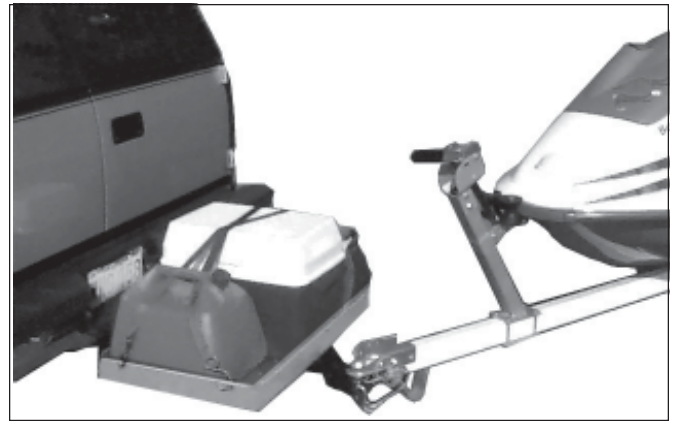

Thank you for purchasing the *TranzSporter Tote n Tow*. Please review the following instructions before starting the assembly. With proper care, the TranzSporter will give you years of service.

Be sure to read the operating instructions and safety information before using your Tote n Tow!

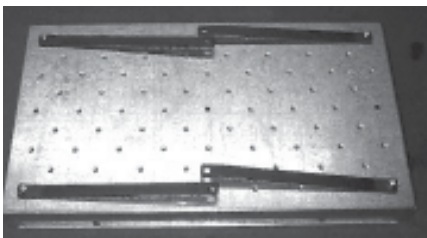

Support bars attached.

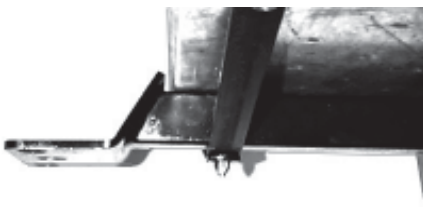
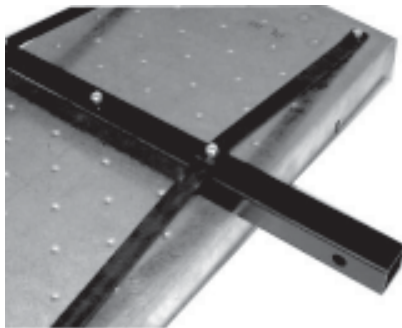

Parts List

Description	Qty
Carrier Pan, 20"x34"	1
Support Bar	4
Receiver Tube w/hitch ball mount	1
3/8"x3" Carriage Bolt	3
3/8"x3/4" Carriage Bolt	4
3/8" Hex Nyloc Nut	7
Wiring Harness Adaptor	1
Cable Ties	2

Hitch Ball Not included

1. With the "Mini" Carriers, you will have extra bolts & nuts that are only used on the larger Utility Carrier. After assembly these can be discarded.
2. Using 4 - 3/8"x3/4" carriage bolts and nyloc nuts, attach the 4 support bars as shown. Carriage bolts are inserted from the inside of the pan. Hand tighten only at this time.
3. Insert the 3/8"x3" carriage bolts through the 3 center holes in the pan. Mount the receiver tube on the bottom of the pan using the 3" carriage bolts. The tube and pan should be assembled with the warning label to the front of the carrier so that it is clearly visible to the person loading the carrier.
4. Attach the support bars to the 2 outer most center bolts with 3/8" nyloc nut on each. Tighten all nyloc nuts at this time. Insert end cap on back side of receiver tube (2" only).
5. Attach the wiring harness adaptor to the support bars with the cable ties provided, so that the male connector will fit into the wiring harness of your vehicle and the other end connects to the trailer wiring.

Instructions Part # 15347
070804,A713

TIE DOWN ENGINEERING • 5901 Wheaton Drive • Atlanta GA, 30336
www.tiedown.com • (404) 344-0000 • Fax (404) 349-0401

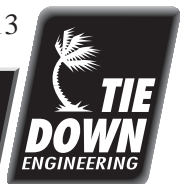

Assembly Instructions
Stk # 86171

Tote N Tow

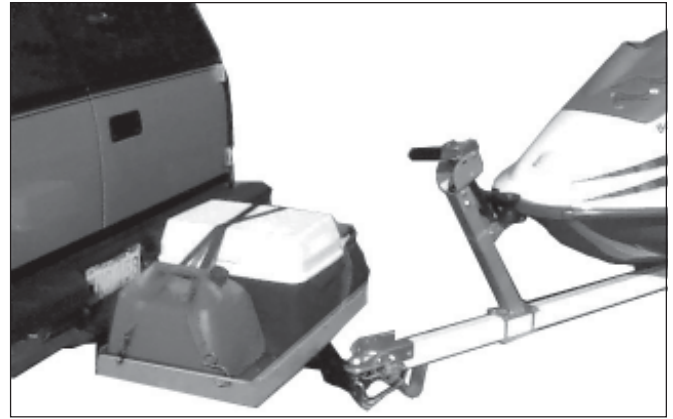

Operation

Insert Utility Carrier mounting tube into hitch receiver of vehicle. Insert locking pin (not provided) through hitch and hole in mounting tube. Attach safety clip to lock pin.

Bolt appropriate size & class hitch ball to the center hole in the mounting plate. Make certain that the hitch ball and coupler size are matched properly. Attach your watercraft trailer to the hitch ball. Use the outward holes for safety chains or cables. Attach vehicle wiring harness to the adaptor wiring harness provided.

! WARNING !

- Trailer weight must never exceed 1,000 lbs gross weight.
- Tote N Tow has a 300 lb carrying capacity or the rated hitch capacity of your vehicle which ever is lower. This is the combined weight of any items placed on the carrier including the trailer tongue weight.
- Trailer tongue weight should never exceed 100 lbs.
- Always secure any items in the carrier to prevent them from falling off.
- Extra distance must be allowed when backing the vehicle.
- Overloading your Tote N Tow may result in reduced front wheel traction and steering.
- Before each use, make certain insert locking pin through hitch hole is secured with lock pin. Make certain that the trailer coupler is attached properly in the locked position and that safety chains or cables are properly attached.

TIE DOWN ENGINEERING • 5901 Wheaton Drive • Atlanta GA, 30336
www.tiedown.com • (404) 344-0000 • Fax (404) 349-0401

