

ABCD/TOW CHARGER/12 VOLT LEAD-ACID BATTERY INSTRUCTIONS AND INSTALLATION

READ THIS FIRST:

Check condition of battery prior to installation and prior to each trip.

1. Remove Charger and Battery from the battery case.
2. Mount battery case securely to frame, jack post or other suitable location on trailer.
3. Bolt Breakaway Switch* to frame of trailer or battery case bracket.
4. Install battery and charger into the battery case. Feed wires out the back, then close the top.
5. Wire per schematic diagram. Properly insulate all connections.
6. For Technical Assistance and Warranty Information call: 1-888-785-5832 or www.tekonsha.com

Important Facts to Remember

1. **CAUTION** Improper installation of the breakaway battery will destroy the brake control. The negative (-) terminal must attach to ground and positive (+) terminal must attach to the breakaway switch.
2. **WARNING** Check your Breakaway System* periodically to insure that wiring and connections are secure. A short or an open circuit can result in a no-brake condition.
3. If excessive discharging of the breakaway battery occurs, check battery and recharge using a Heavy Duty Two Stage /Maintenance Charger. If using a commercial (AC to DC) make certain the 12 volt charge is limited to 1.2 amps or less.
4. If the secondary battery needs charging, current will be drawn from the tow vehicle's battery at anytime the tow vehicle is connected to the trailer. The most current which will be drawn is 1.2 amps.
5. To only charge the breakaway battery when vehicle is running, a battery isolator may be installed in the 12 volt supply line (BLACK wire for tow charger).

12 Volt Sealed Lead-Acid Battery

To maximize the life of the battery the following conditions should be met:

1. Avoid over or undercharge. This is the single worst enemy of lead-acid batteries.
2. Batteries should not be stored in a discharged state or at elevated ambient temperatures.
3. Avoid exposing batteries to heat! Service life is shortened considerably at ambient above 30°C (86°F).
4. Due to the characteristics of this battery, after six to nine months of storage, the battery should be recharged.
5. Charge the battery at the proper rate. Current should be limited to 1.2 amps or less.

6. Provide adequate air circulation when charging battery. Do not charge battery in any other container besides the supplied battery box.
7. **CAUTION** Do not place batteries in close proximity to objects which can produce sparks or flames.
8. Do not expose battery case to organic solvents or adhesives.
9. **CAUTION** Do not attempt to disassemble batteries. Contact with sulfuric acid may cause harm.
10. **CAUTION** Fasten batteries tightly and make provisions for shock absorption if exposure to shock or vibration is likely.
11. **WARNING** Do not throw batteries into fire; batteries so disposed may rupture or explode.

Battery Data Chart

- 12 VOLT
- 4 Amp-hr – max discharge current 20 hr. rate = 225 mA
- 5 Amp-hr – max discharge current 20 hr. rate = 250 mA
- Maximum Discharge Current = 40 amps
- Maximum charge current must be limited to 1.2 amps
- Length = 3.54" Width = 2.76" Height = 4.13"
- Weight = 3.8 lbs
- Terminals: Fasten Tab .187" x .032"
- **Service Life:**
Under normal operating conditions, 4-5 years in standby applications or 200-1000 charge/discharge cycles depending upon depth of discharge and rate of charge.

HEAVY DUTY QUICK/MAINTENANCE TWO STAGE CHARGER

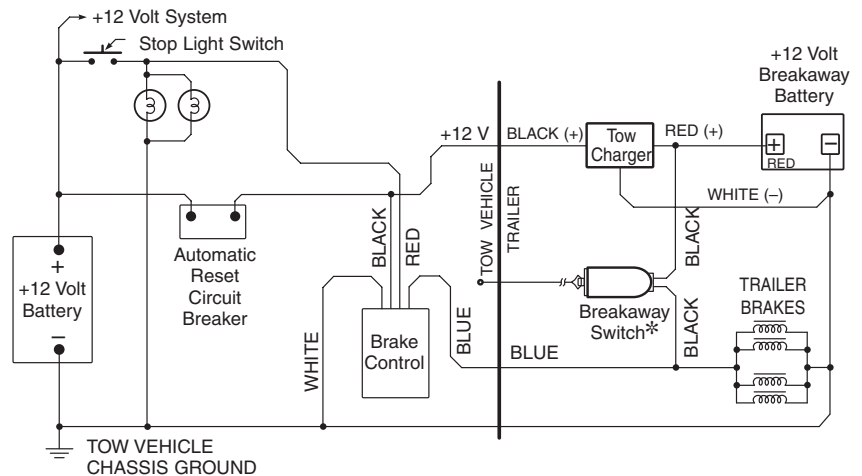

ABCD (Accelerated Battery Charging Device)

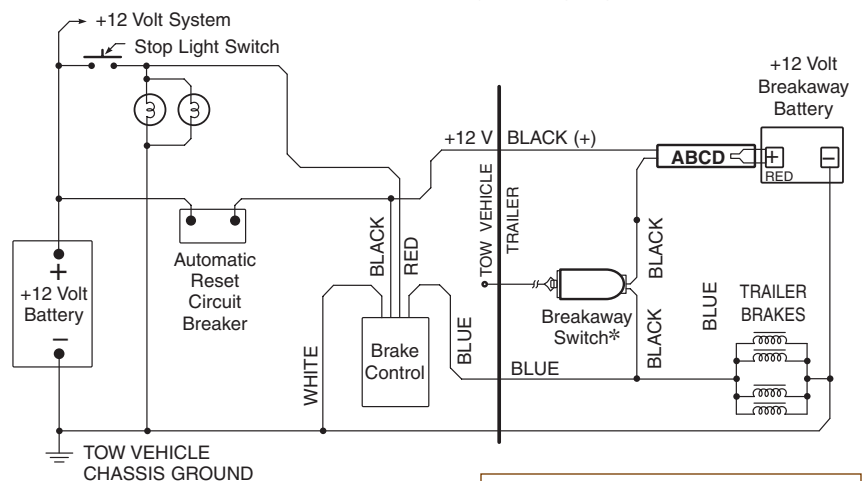

* Refer to Breakaway Switch Installation Instructions for complete operating instructions and cautionary statements.

TECHNICAL INFORMATION IS CURRENT AS OF THE PRINTING OF THIS CATALOG. CONTACT TECHNICAL SERVICE FOR PERIODIC UPDATES.

P/N 2218 REV O

