

OWNER'S MANUAL AND USER'S INSTRUCTIONS

MODEL A-60 & A-70 HYDRAULIC BRAKE ACTUATOR



Breakaway cable clips



See installation instructions
in this manual

TRAILER
Buddy[®]
PRODUCTS BY LFP

San Marcos, CA • Winchester, TN

CONTENTS

WARNINGS	1
INTRODUCTION	1
HOW TO INSTALL THE ACTUATOR	3
TOWING REQUIREMENTS - EQUIPMENT	3
HOW TO ATTACH THE TRAILER	5
SAFETY CHECKS BEFORE TOWING	8
BACKING	10
PARKING AFTER USE	11
PERIODIC INSPECTION AND MAINTENANCE	12
EXTENDED STORAGE MAINTENANCE	14
BRAKE ADJUSTMENT	15
TROUBLESHOOTING BRAKE PROBLEMS	16
HOW TO TAKE APART AND ASSEMBLE THE ACTUATOR	21
MANUAL BLEEDING OF THE BRAKE SYSTEM	24
HOW TO INSTALL THE BREAKAWAY CABLE CLIP ..	26
DEFINITIONS	27
PARTS LIST	28
WARRANTY	Back Cover

WARNINGS

THROUGHOUT THIS MANUAL, THE FOLLOWING SIGNAL WORDS AND SYMBOLS ARE USED TO ALERT YOU TO POTENTIAL HAZARDS. OBEY ALL MESSAGES AND INSTRUCTIONS. FAILURE TO FOLLOW THESE MESSAGES AND INSTRUCTIONS MAY LEAD TO POSSIBLE INJURY OR DEATH.



DANGER indicates an imminently hazardous situation which, if not avoided, will result in death or serious injury.



WARNING indicates a potentially hazardous situation which, if not avoided, will result in death or serious injury.



CAUTION indicates a potentially hazardous situation which, if not avoided, may result in minor or moderate injury.



CAUTION used without the alert symbol indicates a potentially hazardous situation which, if not avoided, may result in property damage.

INTRODUCTION

Your trailer is equipped with the Model A-60 or A-70 Hydraulic Brake Actuator. Trailer brakes will automatically apply whenever the tow vehicle's brakes are applied. They will develop stopping (deceleration) force in direct proportion to the stopping force generated by the tow vehicle.



This actuator should only be installed on trailers with a Gross Vehicle Weight Rating (GVWR) of 6000 lbs. or less (A-60), or GVWR of 7000 lbs. or less (A-70).



This actuator is designed for use with a 2" hitch Ball. The hitch ball and tow vehicle must be rated to handle the actual Gross Vehicle Weight (GVW) of the trailer and load.

ACTUATOR

The Model A-60 actuator maximum load rating is 6000 pounds and the maximum load rating for A-70 is 7000 pounds. Either model can support a maximum static tongue load of 750 pounds. The maximum load rating is for the total weight of the trailer and boat fully loaded including all gear and includes tongue weight.

Read and familiarize yourself with this handbook. Also, review and understand the guidelines and requirements for towing published by the tow vehicle manufacturer and the trailer manufacturer.

Keep this handbook in your tow vehicle or with your trailer for future reference. Contact your dealer or our customer service department if additional information is desired.

You the user are responsible for the consequences of inadequate maintenance, deliberate misuse, alteration or damage to the actuator.

Trailer braking is controlled by the A-60 or A-70 actuator mounted on the tongue of the trailer. When the tow vehicle brakes are applied, the “surge” or “push” of the trailer toward the tow vehicle automatically applies and synchronizes the trailer brakes with the tow vehicle brakes. The coupler slides into the actuator applying force to a piston inside of a master cylinder, which applies the trailer brakes.

HOW THE ACTUATOR WORKS

At constant speed, the brake actuator master cylinder piston is in the free (extended) position; and the trailer brakes are not applied. The shock absorber controls random application of the trailer brakes when towing on rough roads. See Figure 1.

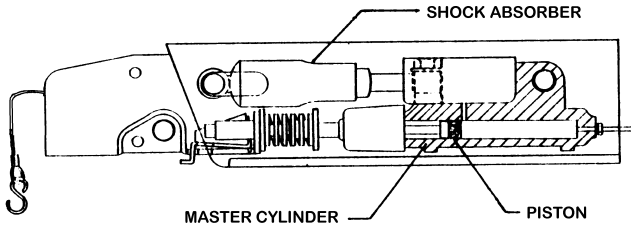

CUTAWAY VIEW

FIGURE 1: ACTUATOR EXTENDED (RUNNING POSITION)

When the tow vehicle slows down, the trailer moves toward the tow vehicle. The actuator slides over the coupler, applying force to the master cylinder piston in direct proportion to how fast the tow vehicle is slowing and how much the trailer weighs. The piston moves into the master cylinder, building pressure to apply the trailer brakes. The shock absorber makes sure the brakes are applied and released smoothly. See Figure 2.

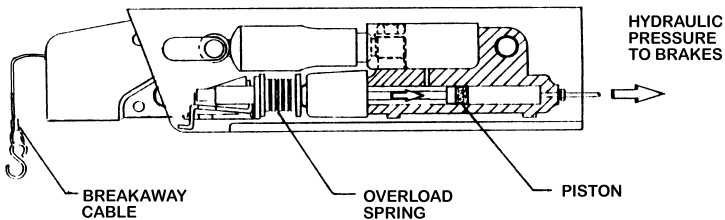

FIGURE 2: ACTUATOR COMPRESSED (STOPPING)

TRAILER BREAKAWAY BRAKES



All actuators must have a way to apply the trailer brakes if the trailer separates from the tow vehicle. The breakaway cable is connected from your actuator to your tow vehicle. If the trailer separates from the hitch ball while towing, this breakaway

cable applies the trailer brakes. The breakaway system must be reset manually after it has been applied.

DO NOT USE THE BREAKAWAY SYSTEM AS A PARKING BRAKE.

HOW TO INSTALL THE ACTUATOR

The actuator is to be used only with brakes specifically designed for trailer service. It should not be used with any custom built, one-of-a-kind brakes because such combinations have not been tested and evaluated. The actuator is designed for use with one or two sets of either 10" or 7" drum breaks. It can also be used with one set of 8 1/2" or 12" drum brakes. The basic actuator may be used with one set of UFP 10" disc or 12" disc brakes. A special version is available for operating 2 sets of 8 1/2" drum brakes and 2 sets of UFP 10" disc brakes. Contact factory for further information.



Some trailers do not have adequate brakes for the trailer, how it is used, or where it is towed. Not having adequate trailer brakes will increase stopping distance and cause more lining wear or overheating

on your vehicle and trailer. You may wish to discuss this subject with your trailer dealer.

TOWING REQUIREMENTS - EQUIPMENT



You must match the tow vehicle and trailer. Also make sure the hitch, hitch ball, and safety chain ratings match or are greater than the trailer Gross Vehicle Weight Rating.

TOW VEHICLE

Review the tow vehicle owner's manual and trailering guide for information on towing capacity, requirements for brakes, use of weight-distributing hitches and other towing recommendations. Make sure your vehicle combination complies with the Gross Combined Weight Rating (GCWR) limits specified by the tow vehicle manufacturer.

BRAKE LAWS

Brake laws vary from state to state. Be sure you understand and comply with regulations. Make sure your vehicle combination has adequate brakes and keep them properly adjusted and in good working condition. Brake laws usually set minimum standards. You may wish to consider a better braking capability depending on the tow vehicle, miles driven and towing terrain.

HITCH

The tow vehicle's hitch must have a rating equal to or greater than the trailer GVWR.

HITCH BALL

The hitch ball must have a rating equal to or greater than the trailer GVWR. Use only a quality machined, or forged ball, with a smooth finish. The actuator coupler will only accept 2" diameter balls. Make certain a 2" diameter ball of the correct load rating is used. Balls must be within the limits of 1.970" - 2.000" diameter when measured in all directions. Balls larger than 2.000" or out of round will not fit the coupler socket. Balls smaller than 1.970" can cause shock loading and a sudden disconnection could result at worse case. Hitch balls may be purchased from your dealer or UFP.

HITCH HEIGHT

For proper tow vehicle and trailer hookup and towing performance, the tow vehicle and trailer are to be level with respect to the ground after hitching up. If your trailer is not level, equipment is available to raise or lower the hitch ball. A weight equalizing hitch or load support suspension equipment may also be required to keep the tow vehicle level and to properly load each axle.

SAFETY CHAINS

Adequate safety chains must be used and conform to the Society of Automotive Engineers (SAE) J684 standard, "TRAILER COUPLING AND HITCHES - AUTOMOTIVE TYPE".



The strength rating of EACH length of safety chain must be equal to the trailer GVWR.

Make sure that your safety chains are fastened to the frame of the trailer and to the hitch or tow vehicle frame. Safety chains fastened directly to the hitch ball or to the bumper, are not acceptable and will not pass vehicle inspections. Connect safety chains using a crossed pattern under the tongue.

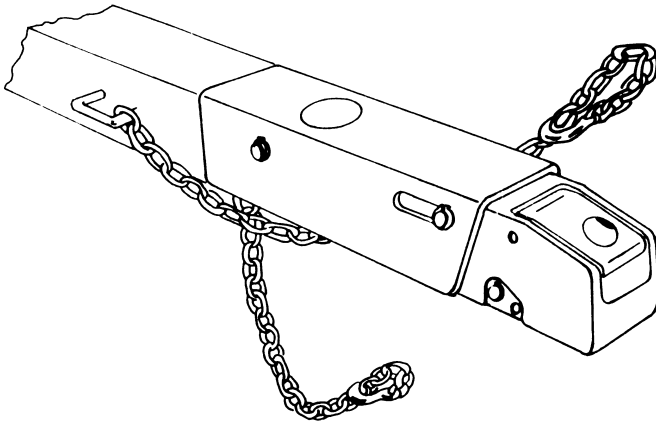

FIGURE 3 TYPICAL DOUBLE SAFETY CHAIN INSTALLATION

SWAY CONTROL DEVICES



Trailer sway control devices that restrict operation of the actuator **MUST NOT** be used. These devices can limit the how much the trailer brakes work.

The coupler must be able to slide freely into and out of the actuator when your vehicle slows down.

WEIGHT DISTRIBUTING HITCHES

Weight distributing (equalizing) hitches may be used. Chain must be vertical (straight up and down) under pulling load (actuator extended). Excessive tongue weight beyond actuator rating must be avoided as it will reduce brake performance and could damage the actuator. Always follow hitch and weight distributing manufacturer's instructions.

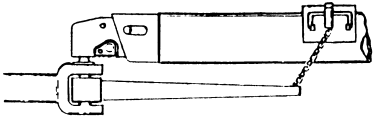

INCORRECT
BRAKES WILL STAY
ON AND OVERHEAT

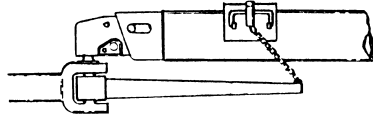

INCORRECT
BRAKING INHIBITED.
STOPPING CAPACITY
REDUCED.

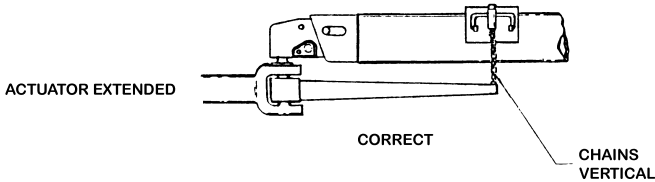

FIGURE 4 TYPICAL WEIGHT DISTRIBUTING HITCH INSTALLATION

HOW TO ATTACH THE TRAILER

To connect the trailer to the tow vehicle, open the coupler mechanism (see instructions below) and if necessary, raise the trailer jack. Slowly back up the tow vehicle so that the hitch ball is under the coupler.



WARNING

Do not move the trailer to the tow vehicle. When the trailer is moved without a tow vehicle, the brakes do not work.

If the latch accidentally opens, the coupler could detach from the hitch ball. The hitch pin should fit easily into the hole (Figure 5). If it does not, the coupler latch is not completely closed. Every time the coupler is attached to the hitch ball, make sure the coupler completely covers the hitch ball and the lift handle will not open without pushing the push button to the side (A-60) or pulling up on the trigger (A-70). If the hitch pin is damaged or lost, contact UFP for a free replacement pin.



WARNING

You must install either the hitch pin (supplied) or a padlock (1/4" or 5/16" shank) into the hitch pin hole before towing to prevent the coupler latch opening accidentally. See figure 5.

TO OPEN THE COUPLER (A-60)

Remove hitch pin from hole in the side of the coupler. Push button on top of handle to the side. While holding button to the side, raise handle by lifting front with two fingers. The coupler should unlatch easily. If not, the ball may be oversized or eggshaped, foreign matter could be lodged in coupler ball socket, or the coupler is pushing on the hitch ball. Check to make sure the wheel on the tongue jack is raised or that you are not parked downhill. Correct these conditions, then try to open the handle. Examples include tongue jack forcing front of trailer up or trailer pushing against tow vehicle. Correct as necessary.

TO CLOSE COUPLER (A-60)

Place coupler over the ball, lower coupler and close handle. You will hear a “click”. Handle should close with finger pressure. If handle will not close freely, ball is not fully inserted into socket, is oversized or eggshaped. **DO NOT FORCE HANDLE.** If necessary, replace ball with a quality unit that meets SAE specifications. Insert hitch pin into hole on side of coupler.

TO OPEN THE COUPLER (A-70)

Remove hitch pin from hole on side of coupler latch handle. While lifting up on latch handle trigger, lift up on latch handle until it rotates about 90 degrees and stops. The coupler should unlatch easily. If not, the ball may be oversized or egg-shaped, foreign matter could be lodged in coupler ball socket, or the coupler is pushing on the hitch ball. Check to make sure the wheel on the tongue jack is raised or that you are not parked downhill. Correct these conditions, then try to open the handle. Examples include tongue jack forcing front of trailer up or trailer pushing against tow vehicle. Correct as necessary.

TO CLOSE COUPLER (A-70)

Place coupler over the ball, lower coupler and close handle. Coupler handle should close with minimal force. If handle does not close, ball is not fully inserted into socket, is oversized or eggshaped. **DO NOT FORCE HANDLE.** If necessary, replace ball with a quality unit that meets SAE specifications. Insert hitch pin into hole on side of coupler latch handle.

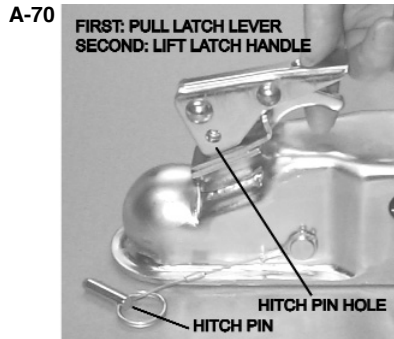
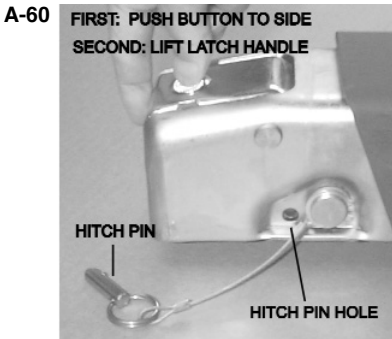

FIGURE 5 OPENING COUPLER



You must install either the hitch pin (supplied) or a padlock (1/4" or 5/16" shank) into the hitch pin hole before towing to prevent the coupler latch opening accidentally. See figure 5.



WARNING

handle opens, the hitch ball is not the right size, oversized, or eggshaped, or the latch parts have been damaged. If the latch is damaged, contact UFP for replacement parts.

DO NOT tow your trailer if latch handle will not remain closed or with the handle open. Check to see if coupler is locked by lifting up on the handle without pushing the button to the side before towing. If the

BREAKAWAY CABLE

Secure the breakaway cable to the bumper or frame of tow vehicle as close to center as possible (do not attach to safety chains). The cable **MUST** hang clear of the trailer tongue and be long enough to permit sharp turns without pulling the cable. Do not loop S-hook over breakaway cable to attach it.



WARNING

Never tow a trailer without the breakaway cable secured to the tow vehicle.

If the breakaway is accidentally pulled and the brakes applied, find out why this happened and fix the problem. Inadvertent setting of the brakes by pulling the breakaway cable is the single most common mistake users make. To prevent light pulls from accidentally setting trailer brakes, a small metal clip has been installed on breakaway cable in front of the indicator bead. The clip will not inhibit the action of the breakaway mechanism during actual breakaway conditions. However, if breakaway should occur the clip will be destroyed and should be replaced. Spare clips are attached to the cover of this manual.

To retract the breakaway cable, slide the coupler fully forward and push up on the pushrod release bracket located on the underside and behind the hitch ball socket to allow the bead to retract into the actuator. This will release the trailer brakes. Install new clip on breakaway cable in front of bead.

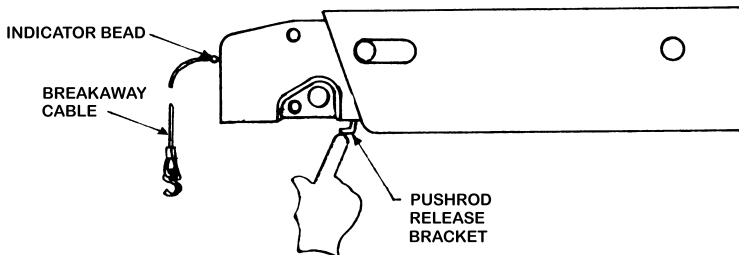

FIGURE 6 CHECKING AND RESETTING BREAKAWAY CABLE

If pushing up on the bracket does not release the brakes or if it is hard to push, insert a pry bar into the 5/16" hole behind the bracket. Use pry bar to stroke push rod backwards to relieve load on bracket. Push up on bracket and hold up while releasing pry bar. The pushrod release bracket should now move freely and brakes should be released. (figure 7)

Check to see if the actuator is reset. Extend the actuator fully. Remove the cap from the top of the actuator and pull the plug from top of the reservoir cover. While looking at fluid in the reservoir, manually compress actuator. In the first 1/8" of coupler movement the fluid in the reservoir should "splash" or "ripple" slightly. If it does, the actuator is working properly.

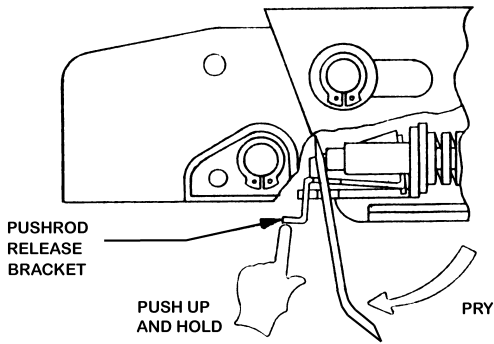

FIGURE 7 STROKING THE PUSHROD TO RELEASE BRAKES

Note: If brakes can not be released using above method or if pushrod release bracket will not move, it is damaged beyond serviceability. Contact UFP for repair parts.

SAFETY CHECKS BEFORE TOWING



FAILURE TO READ AND FOLLOW THESE INSTRUCTIONS MAY RESULT IN SERIOUS INJURY OR DEATH.

ACTUATOR CONDITION

Check the actuator and coupler for damage, bent parts, and excessive wear. Replace parts if needed. Contact UFP for replacement parts. Check that the bolts that attach the actuator (if equipped) to the trailer are tight.



COUPLER

Check that the coupler (latch) handle closes (down) completely when the hitch ball is in the coupler. To make sure the coupler is secured to the hitch ball, look under the coupler and check. Also, while the coupler is attached, raise the front of the trailer 2" to 4" with the tongue jack. If the coupler stays connected, it is secure. If coupler does not stay attached try the attachment and attachment check again. If coupler will not stay attached to hitch ball, or latch opens inadvertently, **DO NOT TOW TRAILER – CONTACT UFP.**

REMEMBER TO LOWER TRAILER/RAISE JACK BEFORE TOWING.

Note: At times the coupler can push on the hitch ball when parked. Check to make sure the tongue jack is raised or that you are not parked downhill. Correct these conditions, then try to open the handle.



TONGUE WEIGHT

It is very important your trailer have 5% to 10% tongue weight when it is loaded and the tongue is level. For example, a trailer weighing 4,000 pounds **MUST** have a tongue weight of at least 200 pounds. This will help reduce trailer from swaying from side to side ("fishtailing"). A bathroom scale can be used to find the tongue weight of the trailer.

Not having enough tongue weight can cause the trailer to sway from side to side and the coupler to rattle up and down as you go down the road. This is very important and if the tongue weight is not in the 5% to 10% range, you should move the cargo (gas tank, anchor, fishing tackle, cooler) from the back to the front or back to front to make sure the tongue weight is in the range. On some trailers, the axle or axles can be moved to change the tongue weight.



BREAKAWAY CABLE

Check the breakaway cable each time before you tow and at gas and rest stops to make sure it has not been damaged. Check the location of the

indicator bead and clip. The clip should be in place and the bead should not be outside the actuator. Accidental application will cause brakes to drag and heat up.



SAFETY CHAINS

Make sure that your safety chains are secured to the tow vehicle per the instructions supplied by trailer manufacturer. SAE recommendations are listed in “Requirements-Equipment” section.



FLUID LEVEL

Check the fluid in the master cylinder reservoir each time before you tow or if you see break fluid leakage. Refill as required.



HITCH BALL

Make sure a 2” diameter ball of correct load rating is used. A film of clean grease on the ball will extend coupler and ball life and stop squeaking. Wipe ball clean and renew film periodically.



TOW VEHICLE HITCH

The hitch on the tow vehicle must be of the proper load rating and in good condition. If hitch is of the receiver type, make sure receiver pull pin is in place and safety pin is installed.



TRAILER JACK

Trailer jack must be fully retracted and caster wheel removed (if necessary) before towing.



AUTOMATIC BRAKE LOCKOUT (if equipped)

The electrical lead from the solenoid valve must be connected to the tow vehicle backup lights. A “click” should be heard when the tow vehicle is shifted into reverse and the backup lights come on.

To check: Have someone listen for the sound while driver is in the tow vehicle. Keep the emergency brake on and one foot on the brake pedal to avoid accidentally backing up.



ELECTRICAL WIRING

Plug in connector and check signal, brake and running lights.

BACKING

When you back your car and trailer, the coupler will move back and apply the trailer brakes. The brakes will apply at different levels depending on how fast you back up, the type of brakes, the road or surface you are on, and the angle of your trailer. If your trailer has drum brakes, most of the time the trailer brakes won't be a problem when backing up. Below are options that help you back up with the trailer brakes.

Some trailers with disc brakes need an electrical solenoid control to allow the trailer to back up. This control is wired th the back up lights on the tow vehicle and when the tow vehicle is put into reverse, this control dose not allow the trailer brakes to apply.

BRAKE LOCKOUT BRACKET

A simple lockout is included on some models to stop the coupler from moving back when you back the trailer. The brake lockout bracket is used when you need to back over soft ground or up a hill. Use it as follows:

1. Put or place the brake lockout into slot behind roller pin on the side of the actuator.
2. Slide the brake lockout completely forward in slot. Washer will keep brake lockout from falling out while backing up.

When you pull the trailer forward and the actuator extends, the brake lockout should fall out of the slot. This makes sure the actuator will function when stopping.



THE BRAKE LOCKOUT BRACKET MUST BE REMOVED BEFORE TOWING OR THE TRAILER BRAKES WILL NOT WORK.

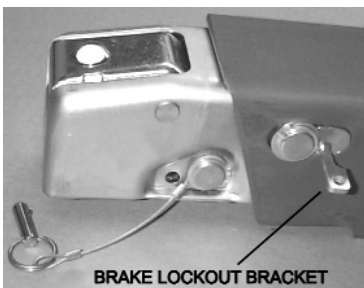

FIGURE 8

BRAKE LOCKOUT CAP

This type of lockout is an available option. It allows trailers to be backed up over soft ground or up inclines without fully engaging the brakes. This lockout is designed to disengage when the trailer is pulled forward after backing up. Therefore it must be manually reset prior to each back up.

Operating Brake Lockout Cap

1. To operate lockout cap, the actuator must be fully extended. This can be done by pulling the trailer forward slowly.
2. With the lockout cap in the TOW (forward) position, depress the button in the front of the cap and rotate the cap clockwise toward the BACKING position until it stops. The button should remain down.
3. Back the trailer.

4. If the trailer needs to be pulled forward, there are two options:
 - a) Pull the trailer forward and let the coupler move forward. The control cap will rotate (reset) and you will have to turn it back to the BACKING position in order to back up.
 - b) If you have backed up an incline, allow the tow vehicle to move forward slowly so the coupler stays back. This keeps the control in the engaged (BACKING) position so you can back up again.



After the trailer is removed from the tow vehicle after backing up, block the trailer wheels, and move the coupler all the way forward by hand. This will remove the lockout and moved the cap to the TOW

position. BE CAREFUL – if trailer is parked downhill, it may roll forward.

Remove Brake Lockout Cap

1. Make sure the coupler is moved all the way forward.
2. With the cap in the TOW position, press the button and rotate the cap counterclockwise toward the REMOVE position until it stops.
3. Lift the cap up to remove it and gain access to the master cylinder reservoir.



Before towing trailer, be sure that the lockout cap is working properly, the cap button is up and cap is in the normal TOW position. If cap does not reset or work properly remove cap from trailer. If you do not

remove a cap that does not work, it may cause the trailer brakes not to work properly.

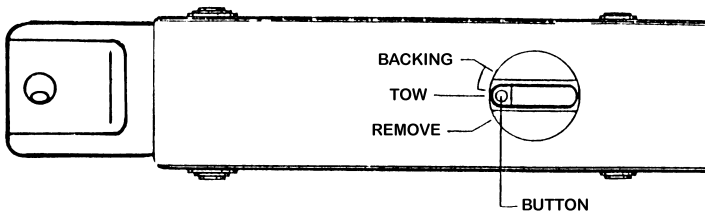

FIGURE 9 BRAKE LOCKOUT CAP

Automatic Brake Lockout

An automatic brake lockout is recommended if the trailer has disc brakes. Whenever you back up, a 12 volt electrical signal from the tow vehicle backup light circuit energizes the pressure control unit. Hydraulic pressure is prevented from building up so the brakes will not come on.

The electrical control may also be used with drum brakes. To change the existing master cylinder in the actuator will have to be replaced. Call UFP if you want to make this change.

PARKING AFTER USE



After parking the trailer ALWAYS move the coupler all the way forward by hand to keep moisture from coming in contact and corroding the master cylinder bore. If trailer has been in salt water, rinse off trailer

and flush out the brake drums or rotors with fresh water.



CAUTION

If you are not skilled in the following procedures, we recommend you contact your dealer for this service. If you have any questions contact our customer service department at (760) 744-1610.

PERIODIC INSPECTION AND MAINTENANCE

In order to ensure efficient operation, the following checkpoints should be observed annually or every 2000 miles, whichever occurs first.

1. Inspect tow hitch per tow hitch manufacturer's instructions for corrosion or damage. Repair or replace components as necessary.
2. Check for wear on hitch ball. Ball diameter must be in the range of 1.970" - 2.000" when measured in all directions. If ball is worn, it is **UNSAFE** and must be replaced. It could cause improper brake performance, separation of ball and actuator, or noisy and jerky trailer operation.
3. Check coupler latch operation for excessive wear and fit on ball. Check fit on ball as outlined in "Coupler" section of the "Safety Checks Before Towing" Section.



WARNING

A loose fit may allow coupler portion of actuator and ball to separate.

4. Check coupler mechanism for smooth operation. If button is hard to push or latch handle does not spring open after being disengaged, lubricate points on coupler latch mechanism indicated by arrows in Figure 12. (A-60 only)

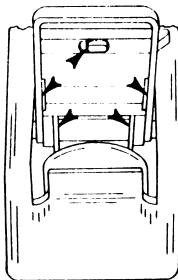

FRONT VIEW
(LATCH OPEN)

ARROWS
INDICATE
LIGHT OIL
OR
WD-40

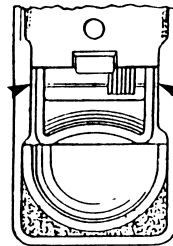

BOTTOM VIEW

FIGURE 10 COUPLER LUBRICATION POINTS

5. Check actuator for excessive wear. If the outer member is rubbing against the inner member, wear marks will show on top coupler just forward of outer member. Contact factory for replacement parts.
6. Check actuator travel. Excessive actuator travel (over one inch) when brakes are applied indicates a need to adjust the brakes (not necessary with disc brakes) or air in the brake lines.

7. Check brake fluid in the master cylinder reservoir. To gain access to the reservoir, remove the cap on top of the actuator. Clean area around master cylinder plug. Use a screwdriver to carefully pry off plug. Make sure rubber seal around opening is in good condition. Clean brake fluid off level indicator on plug. Re-install and remove plug. Brake fluid should just touch the end of the level indicator.
8. Check for foam or bubbles in the brake fluid. If either are present, drain fluid from master cylinder and replace only with new brake fluid of the same type, (DOT 3 or 4). In order for brakes to function properly all air must be expelled from the brake system. If bleeding is necessary, follow "MANUAL BLEEDING OF THE BRAKE SYSTEM" instructions as outlined in this booklet.

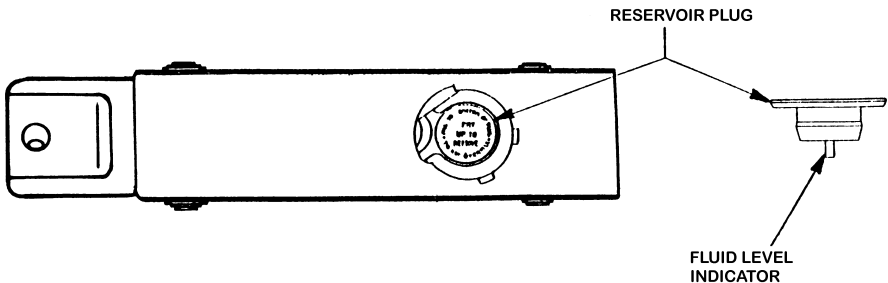

FIGURE 11 MASTER CYLINDER RESERVOIR PLUG

NOTE: It is imperative that the system be filled with only ONE type of brake fluid. Different types do not mix. DOT 3 and 4 are used by most manufacturers. Follow instructions on brake fluid container.

9. Check safety chains and attachment points for damage or wear. Repair or replace as necessary.
10. Check the breakaway cable for worn or frayed cable strands. End fittings should be checked for damage. Replace if necessary.
11. Check for any hydraulic leaks in the brake system. Be sure all tube fittings are tight. Periodic checks must be made on all hoses, brake line tubing and fittings to guard against cuts, worn hoses and loose fittings which may cause leaks in trailer brake hydraulic system. Replace deteriorated and damaged parts as necessary.
12. Check brake adjustment (not necessary for disc brakes) after first 300 miles and every 2000 miles thereafter. **PROPER ADJUSTMENT OF BRAKES IS EXTREMELY IMPORTANT FOR STOPPING CAPABILITY.** If brakes are in need of adjustment, we recommend that you follow the manufacturer's instructions or steps outlined in this booklet.

EXTENDED STORAGE MAINTENANCE

(Over one year)

The following preventive maintenance is recommended for extended periods of storage.

1. Check brake system for fluid level in master cylinder. If fluid level is extremely low, air may be trapped in brake lines. Bleed all lines if necessary and fill reservoir to proper level.
2. Lubricate all links and pivots to prevent rusting.

If equipped with drum brakes and storage is in a humid environment, remove wheel and drum assemblies and spray a good anti-corrosion compound (CRC Formula 5-56, for example) under rubber boot on forward end of brake wheel cylinder. Also, spray springs, adjuster and anchor pin.



Avoid spraying drum and brake lining surfaces.

3. Grease bearings, fill hub cavities and reinstall wheel and drum assemblies.
4. Top off bearing protectors, if equipped, with grease.
5. Make sure breakaway system has not been set, and actuator is fully extended.
6. If possible, store away from excessive moisture.

BRAKE ADJUSTMENT

Raise one trailer wheel at a time, remove the dust cover from the adjusting slot at the lower part of the back side of the brake assembly. Insert brake adjusting tool or screwdriver as shown. Adjust brake shoes out until wheels will not rotate in the forward direction by moving the end of the adjusting tool toward top of brake as illustrated. When this condition is felt, back off (loosen) the adjustment as follows:

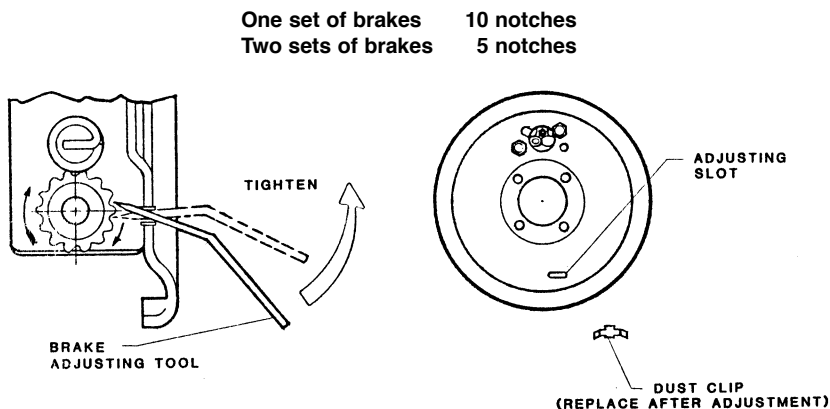

FIGURE 12 ADJUSTING BRAKES

Note: UFP 10" brake drums have a hole on the front side to permit brake lining inspection and access to the brake shoe adjustment star wheel. Simply remove the trailer wheel to access the inspection hole.

We recommend that your trailer brakes be adjusted after the first 300 miles of use and at least every 2,000 miles thereafter. In addition, the trailer brakes should also be inspected after the first two years of service for wear and corrosion (one year after substantial salt-water immersion). Service, lubricate and/or replace parts as necessary for safe, sure operation. Thereafter, set up a maintenance schedule that assures proper inspection and adjustment of brakes. The time interval should be based on towing conditions, operating environment (salt vs. fresh water, etc.) distance towed, storage conditions, etc. The goal is simple. Make sure your brakes will work properly when you need them most, in an emergency stop. Plated and galvanized brakes are now available and are better able to withstand corrosion.

HYDRAULIC DISC BRAKE ADJUSTMENT

Hydraulic disc brake adjustment is not necessary, they are self-adjusting.

TROUBLESHOOTING BRAKE PROBLEMS



If any of the following problems develop, the trailer must be immediately stopped and the proper corrective action taken before the trailer is put back into service. Failure to do so may lead to loss of

proper trailer braking capability, or damage to the trailer and load.

PROBLEM: COUPLER LATCH HANDLE DOES NOT OPEN OR CLOSE EASILY	
POSSIBLE CAUSE	REMEDY
Oversize hitch ball	Check ball size at several positions, ball should be within 1.970"-2.000" in diameter. Replace if necessary.
Ball not fully inserted in ball socket.	Check for proper ball size, (see above) and positive tongue load. Check to see if tongue jack is fully retracted. Make sure there are no foreign objects or excessive paint inside coupler cavity.
Trailer and tow vehicle are not level with each other, or are facing downhill.	Reposition tow vehicle and trailer or block trailer tire and extend actuator.
Excessive corrosion	Lubricate or replace parts as necessary.



If the latch handle does not close freely, **DO NOT** tow the trailer until cause of the problem is located and eliminated. Forcing latch handle closed will make opening latch handle extremely difficult.

PROBLEM: SQUEAKING, CLUNKING AND CLATTERING AT ACTUATOR

POSSIBLE CAUSE	REMEDY
Hitch ball requires lubrication.	Lubricate with conventional multipurpose lubricant or commercial lubricant made for hitch balls.
Loose hitch ball	Inspect hitch ball and tighten.
Loose hitch	Inspect hitch and repair.
Loose mounting bolts (if equipped)	Inspect brake actuator mounting bolts and tighten as necessary, (70-80 ft-lbs).
A worn or too small hitch ball.	Replace hitch ball with a quality unit that meets SAE specifications.
Worn shock absorber	Replace shock absorber.
Air in brake lines allowing actuator to travel too far.	Check for leaks, re-bleed brakes.
Trailer is equipped with "free backing brakes".	Clunking noise is typical for these types of brakes as long as braking performance is normal.

PROBLEM: WHEN BRAKING, BRAKES REPEATEDLY COME ON AND RELEASE, BRAKING IS NOT SMOOTH, THIS CONDITION IS CALLED "CHUCKING"

Worn out shock absorber in actuator.	Replace the shock absorber.
Loose hitch or hitch ball.	Correct as necessary.
Not enough tongue weight or shocks on tow vehicle too soft.	Correct as necessary.
Air in the brake lines.	Bleed the brake system.
Brakes out of adjustment.	Adjust the brakes properly.
Contaminated brake linings.	Fix cause of contamination (leaky wheel cylinder or hub grease seal). Replace linings and clean braking surface on drum or rotor.
Rusted master cylinder bore.	Replace actuator master cylinder.
Breakaway cable has been pulled.	Reset push rod release bracket.

PROBLEM: BRAKES DO NOT OPERATE, POOR BRAKE PERFORMANCE

POSSIBLE CAUSE	REMEDY
<p>Worn out brake shoes or disc brake pads.</p> <p>Foreign material in the brake unit assembly.</p> <p>Insufficient amount of hydraulic fluid.</p> <p>Broken lines or pinched line.</p> <p>Seized actuator master cylinder. Prevents piston from stroking.</p> <p>Corrosion/rust keeps brake from operating.</p> <p>Inadequate brakes for load or driving conditions.</p>	<p>Replace brake shoes/pads on both sides of axles and check drums/rotors for wear or damage.</p> <p>Clean thoroughly. Replace shoes and linings if contaminated.</p> <p>Fill reservoir and bleed brakes. Check for leaks.</p> <p>Replace faulty lines and bleed brakes.</p> <p>Replace actuator master cylinder.</p> <p>Replace damaged components or entire brake assembly as required.</p> <p>If you have a tandem axle trailer add a second set of brakes.</p>

DRUM BRAKES ONLY

<p>Incorrect adjustment of drum brake.</p> <p>Broken components in brake assembly.</p> <p>Leaky or seized brake wheel cylinder.</p>	<p>Adjust all brakes.</p> <p>Replace faulty parts and re-adjust brakes.</p> <p>Replace/rebuild wheel cylinder and replace brake shoes (if contaminated with brake fluid). Clean drums and other hardware, readjust brakes and bleed brake system.</p>
---	---

PROBLEM: ONE BRAKE OVERHEATING

POSSIBLE CAUSE	REMEDY
Drum brake adjusted too tightly. Disc brake caliper does not permit brake pads to release. Leaky or seized brake wheel cylinder. Damaged or frozen brake mechanism.	Readjust, check all brakes. Check Caliper. Sections must be free to move apart. If frozen, remove and free up. Caliper piston may freeze up and prevent pads from retracting. Clean contaminants out of piston cavity. Replace piston, seal and protective dust cover boot. Bleed system. Replace/rebuild wheel cylinder and replace brake shoes (if contaminated with brake fluid). Clean drums and other hardware, readjust brakes and bleed brake system. Rebuild or replace brake unit.

PROBLEM: BOTH BRAKES OVERHEATING

Isolate the problem to actuator or the brakes as follows:

1. Fully extend actuator.
2. Remove master cylinder reservoir plug.
3. Check that reservoir is properly filled.
4. Manually push the actuator inner member in or use a screwdriver to stroke pushrod. (Be sure to depress the pushrod release button after stroking pushrod).
5. In the first 1/8" of stroke, the reservoir fluid will either remain dead calm or swirl around.

If the fluid swirls:

Fluid is allowed to return to reservoir when actuator is extended.

Actuator is functioning properly, troubleshoot brakes.

POSSIBLE CAUSE	REMEDY
Drum brakes misadjusted. Trailer stored with actuator compressed; rust has caused both brakes to freeze up. Inadequate brakes for towed load or driving conditions. Pinched or kinks in brake lines.	Adjust brakes properly. Remove brakes. Clean, repair or replace components as necessary. If you have a tandem axle trailer add a second set of brakes. Check brake lines and replace as necessary.

If fluid does NOT move:
Brake system is remaining pressurized and there is an actuator problem.
Troubleshoot actuator.

POSSIBLE CAUSE

REMEDY

Pulled breakaway cable, pushrod not reset

Reset breakaway cable, install clip.

For each of the following the actuator inner member must be removed. Follow the instruction in "HOW TO TAKE APART AND ASSEMBLE THE ACTUATOR".

Fluid return hole in master cylinder clogged or mispositioned.

Corrosion in master cylinder freezing up piston or not allowing it to fully retract, usually caused by railer stored with actuator compressed.

Other malfunction or damage keeping the master cylinder piston from retracting.

Troubleshoot.
Replace parts as necessary.

HOW TO TAKE APART AND ASSEMBLE THE ACTUATOR

DISMANTLING ACTUATOR

Note: Read and understand this section before attempting to disassemble inner member.

1. Extend actuator and remove cap from top.
2. Unscrew brake line fitting from rear of master cylinder. **Note:** Brake fluid escaping from master cylinder and brake line will damage paint. Care should be taken to protect painted surfaces.
3. Remove one retaining ring and washer from each of the two roller pins located on side of actuator main body and slide pins out.
4. Pull on brakeaway cable to remove inner member. This ensures that all components will come out attached together. Internal components can now be removed and dismantled for inspection, maintenance or repair. Entire inner member can be replaced.

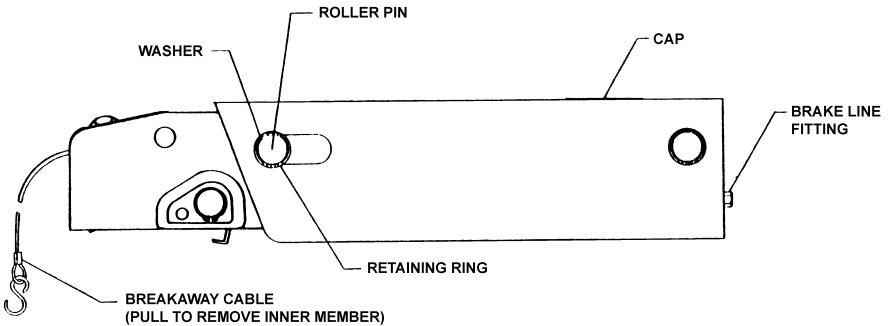
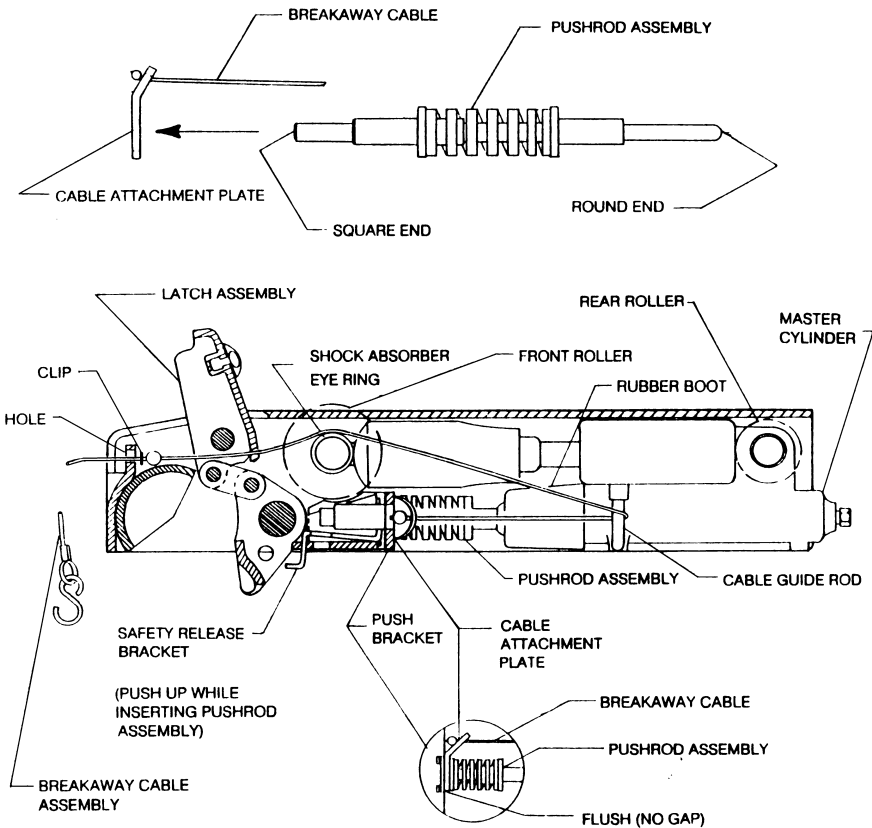

FIGURE 14 ACTUATOR, SIDE VIEW

ACTUATOR ASSEMBLY

Before the inner member can be inserted into the main body all internal components must be assembled and placed in their proper position.

1. For ease of assembly, assemble inner member upside down.
2. Check that shock absorber, reservoir cover plate, diaphragm, and plug are assembled to the master cylinder.
3. Insert ball end of breakaway cable through hole in front of inner member, thread through latch assembly and around out side of cable guide rod located on the side of master cylinder. Ball end of cable can now be inserted into hole on cable attachment plate and slid over into slot. Note orientation of cable attachment plate.
4. Insert square end of push rod assembly into hole in cable attachment plate. Insert round end of push rod assembly through rubber boot and into master cylinder piston.
5. Lightly grease rear rollers and hold them in the pockets in the sides of the master cylinder while inserting entire assembly into the inner member from the back end. While inserting assembly make sure push rod enters hole in push rod bracket. The tab on the safety release bracket will have to be depressed to allow push rod assembly to fully enter hole in push bracket. The cable attachment plate should sit flush with the push bracket if properly assembled.
6. Make sure breakaway cable is correctly routed and is not wrapped around or hung up on any components.
7. While supporting the master cylinder, turn inner member assembly over and lightly grease front rollers and insert them through the openings on top of inner member. Note: Before inserting rollers make sure breakaway cable runs on top of shock absorber eye ring. Install top pad on top of the actuator in the roller slots.
8. Slide actuator inner member into outer member and line up roller pin holes on rear of actuator first. Insert lightly greased roller pin.
9. Push or pull inner member to line up holes in rollers with hole in shock absorber eye-ring and insert lightly greased roller pin.
10. Pull on inner member to the fully extended position. With slack taken out of breakaway cable, check that the cable clip is in place next to the indicator bead. Push up on safety release bracket tab to reset breakaway system.
11. Assemble washers and retaining rings on roller pins.
12. Connect brake line fittings and install cap.
13. Bleed brake system according to instructions outlined in "MANUAL BLEEDING OF THE BRAKE SYSTEM" section.



BOTTOM VIEW

NOTE: ORIENTATION OF CABLE ATTACHMENT PLATE IS TOWARD SIDE OF INNER MEMBER.

FIGURE 13 COMPONENT LOCATION (A-60 Inner Member)

MANUAL BLEEDING OF THE BRAKE SYSTEM



If you are not skilled in performing the following procedures, have a qualified service shop perform the job.

Check that all hydraulic fittings are secure. Read and understand all instructions before starting. Two people are required for manual bleeding.

1. Remove the master cylinder reservoir plug and fill the reservoir with brake fluid. Use either DOT 3 or DOT 4 automotive brake fluid. Follow instructions on brake fluid container. Avoid shaking brake fluid container and pour fluid slowly to minimize air entrapment. Let fluid in reservoir stand until completely free of air bubbles.
2. **IMPORTANT:** Before bleeding brake lines, bleed the actuator master cylinder. Insert a screw driver through hole in bottom of inner member and use short strokes to pry on pushrod (while holding safety release bracket up) until no air bubbles are seen coming from small orifice hole in the bottom of the master cylinder reservoir.
3. Start bleeding procedure on the brake furthest from master cylinder.
4. At the brake assembly, connect a transparent bleeder hose to bleed screw fitting on wheel cylinder and submerge free end into a container partially filled with brake fluid. Do not reuse this fluid.
5. The first person strokes the pushrod slowly while holding safety release bracket up. The second person opens the bleed screw fitting. He then closes the bleed screw fitting **BEFORE** the first person **SLOWLY** releases the pushrod. Repeat this procedure until the fluid expelled from the bleeder hose is free of air bubbles. Remember to always tighten the bleeder screw before releasing pushrod. During this procedure, the master cylinder reservoir fluid level must be maintained at no less than 1/2 full.
6. Repeat steps 4 and 5 for the other brake and the brakes on the front axle, if equipped with tandem brake axles.
7. If installation is tandem axle with brakes on both axles, repeat bleeding procedure on rear axle brakes for the second time to assure purging of all air in system.
8. As a final check after bleeding is completed, stroke pushrod and check to be sure brake system is pressurized by attempting to rotate a tire.
9. Push up on the safety release bracket to ensure that pushrod is in released position.
10. After bleeding has been completed, re-check fluid level in master cylinder. Fill the master cylinder reservoir to indicator on reservoir plug. Do not overfill.

CAUTION

IMPORTANT: DO NOT USE BRAKE FLUID DRAINED FROM BRAKE SYSTEM TO REFILL MASTER CYLINDER RESERVOIR AS SUCH FLUIDS CONTAIN CONTAMINANTS FROM SYSTEM WHICH MAY

RESULT IN BRAKE FAILURE OR COSTLY REPAIRS.

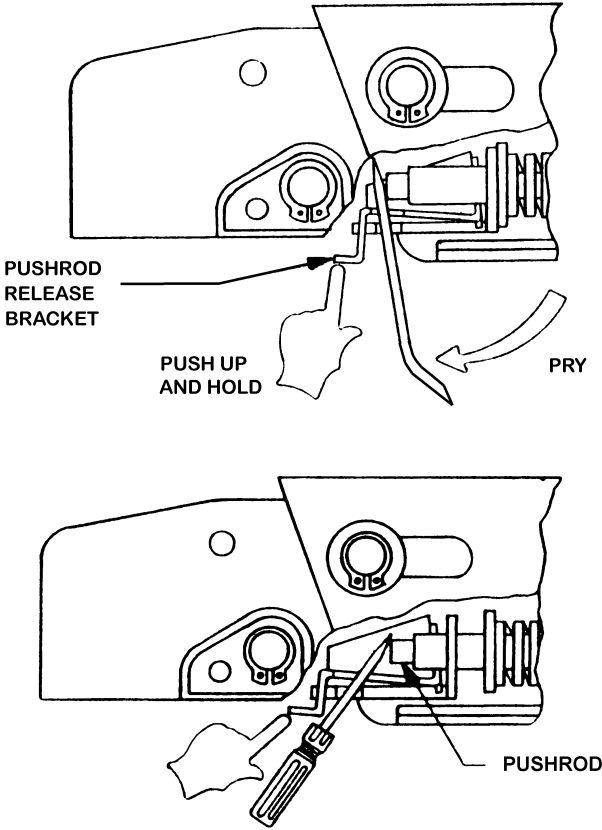

FIGURE 16 STROKING PUSHROD TO BLEED BRAKES

HOW TO INSTALL THE BREAKAWAY CABLE CLIP

The breakaway cable clip is installed on the breakaway cable to prevent inadvertent pressurization of trailer breaks if cable is lightly pulled accidentally. Should the breakaway cable be pulled, during emergency situations, the clip will be destroyed. The breakaway system must be reset by pushing up on the tab located under coupler and the clip must be replaced.

A-60

To install clip, open latch handle and pull enough cable out of coupler body to make installation of clip easier. Clip must be installed on cable in front of indicator bead as shown below.

A-70

Install clip from bottom side of coupler by locating cable and installing clip in front of indicator bead.

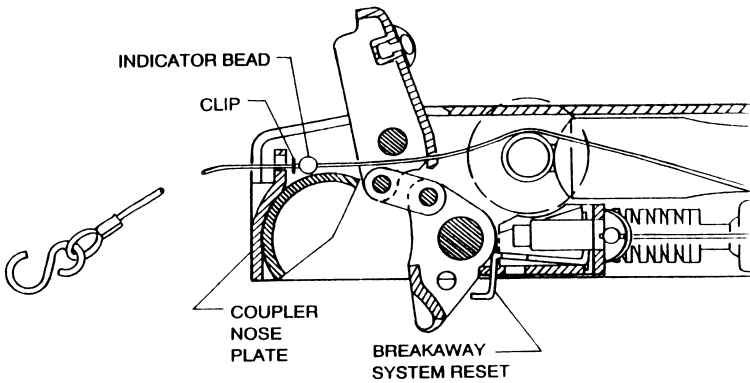

Hold Clip with pliers and insert over cable. Use a second set of pliers to gently close the opened end of clip. Clip should be free to move on cable

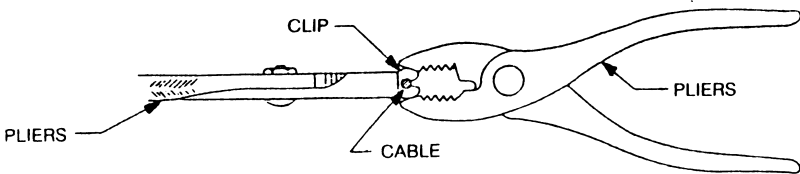

The breakaway system reset tab must be pushed up after clip installation and anytime the cable has been pulled.

A-60 / A-70 ACTUATOR DEFINITIONS

ACTUATOR - The device on the front of the trailer, which operates the trailer's brakes in proportion to the tow vehicle stopping.

GROSS VEHICLE WEIGHT RATING (GVWR) - This rating is found on the trailer's identification plate. The rating includes the total weight of the trailer and all cargo that it is carrying.

A-60 ACTUATOR - An actuator manufactured by UFP with a maximum trailer GVWR of 6,000 lbs and maximum tongue load of 750 lbs.

A-70 ACTUATOR - An actuator manufactured by UFP with a maximum trailer GVWR of 7,000 lbs and maximum tongue load of 750 lbs.

COUPLER - The portion of the actuator that receives and secures the tow vehicle hitch ball during towing.

MASTER CYLINDER - A hydraulic device in the actuator that supplies brake fluid under pressure to the trailer's brakes in proportion to an input force.

VEHICLE COMBINATION - The combination of the tow vehicle and the trailer.

HITCH - An apparatus attached under the rear of the tow vehicle that transfers the trailer's tongue and towing loads to the tow vehicle.

HITCH BALL - A round ball on a shank attached to the hitch of the tow vehicle used to connect the trailer to the tow vehicle.

SAFETY CHAINS - An assembly, which provides a secondary means of connection between the rear of the towing vehicle and the front of the trailer.

WEIGHT DISTRIBUTING HITCH - A device that transmits the tongue load of the trailer from the rear wheels of the tow vehicle to the front wheels of the tow vehicle.

SOCIETY OF AUTOMOTIVE ENGINEERS (SAE) J684 STANDARD - This SAE Standard includes couplings, hitches, and safety chains used in conjunction with all types of trailers or towed vehicles whose Gross Vehicle Weight Rating (GVWR) does not exceed 10,000 lbs.

TRAILER SWAY CONTROL DEVICES - After market devices intended to eliminate or control the amount of trailer sway (side to side movement) during towing.

PUSHROD RELEASE BRACKET - A part of the actuator that holds the master cylinder pushrod in the engaged position supplying constant pressure to the trailer brakes when the safety cable has been pulled.

TONGUE WEIGHT - A portion of the total trailer weight that is supported by the coupler.

LOAD RATING - The maximum load that a component or device can safely carry or support without failure.

BRAKE LOCKOUT CAP - An optional device that is located on top of the UFP actuator that allows the trailer to be backed up over soft ground or up an incline without fully engaging the trailer brakes.

BRAKE LOCKOUT BRACKET - A device that is inserted into the side of the UFP actuator that allows the trailer to be backed up over soft ground or up an incline without fully engaging the trailer brakes.

PARTS LIST

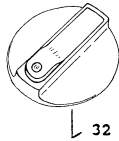
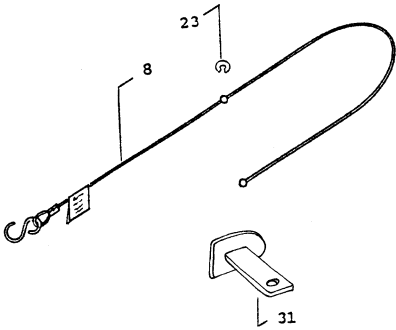
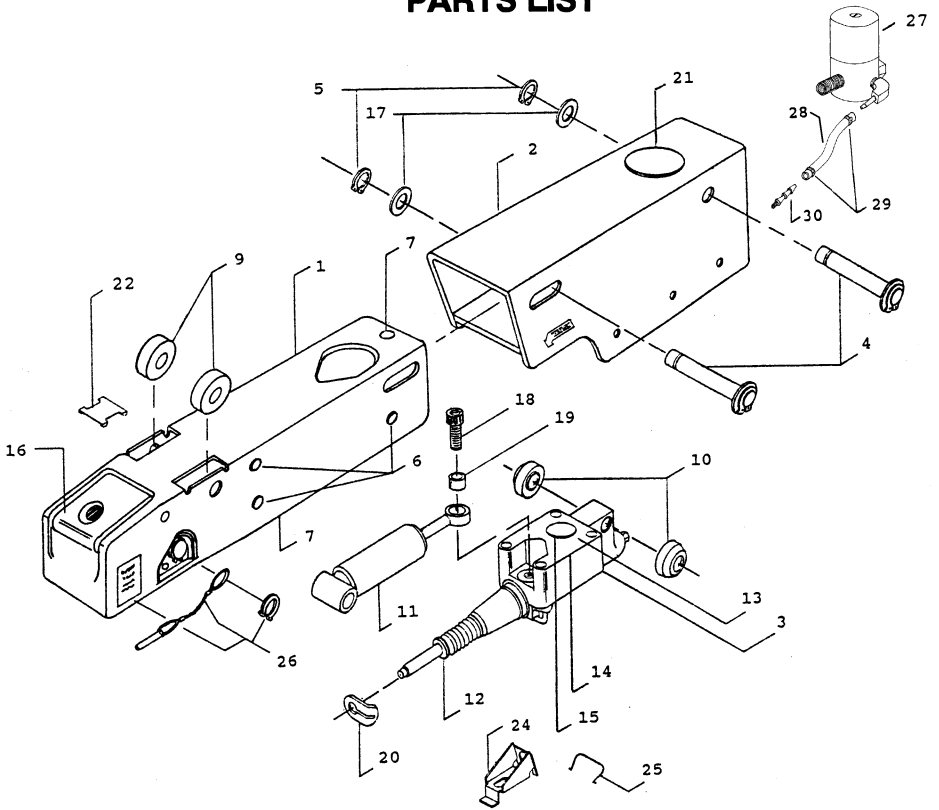

SEE PAGE 8

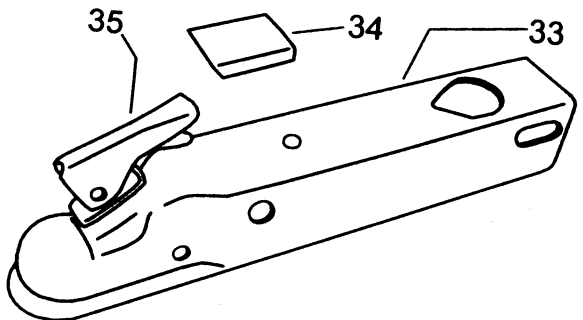

ITEM NO.	PART NO.	DESCRIPTION	QUANTITY
1	34021	A-60 Inner Member, Primary Assy.	1
2	various	Outer Member	1
3	35154	Master Cylinder Assembly	1
	34762	Master Cylinder for use w/Solenoid	1
4	34079	Roller Pin	2
5	32262	Retaining Ring	2*
6	32260	Wear Pad, Thin (sides)	6
7	32263	Wear Pad, Thick (top/bottom)	3
8	34370	Breakaway Cable Assembly	1
9	34371	Front Roller (A-60 only)	2
10	32310	Rear Roller	2
11	32306	Shock Absorber	1
12	35112	Pushrod Assembly	1
13	34300	Reservoir Plate Cover	1
14	32288	Reservoir Diaphragm	1
15	32286	Reservoir Plug	1
16	36360	A-60 Latch Replacement Kit	1
17	32554	Roller Pin Washer	2*
18	32291	3/8-16 x 1.00" Bolt	1
19	34301	Shock Absorber Bushing	1
20	34380	Cable Attachment Plate	1
21	32547	Outer Member Cap, Plastic	1
22	32592	A-60 Top Pad	1
23	34355	Breakaway Cable Clip	1
24	34378	Pushrod Release Bracket	1
25	32546	Pushrod Release Bracket Spring	1
26	34545	Hitch Pin Kit (Pin, Decal & Retainer)	1
27	34500	Solenoid Valve with Fittings	1**
28	34508	Reverse Valve Drain Tube	1**
29	32269	Nylon Cable Tie	2**
30	32570	#10-32 Mini-Barb Fitting	1**
31	34557	Side Lockout Kit	
32	34359	Top Lockout Upgrade	
33	47720	A-70 Inner Member, Primary Assy.	1
34	47710	A-70 Top Pad	1
35	36368	A-70 Latch Replacement Kit	1
36	34566	A-70 Hitch Pin Kit	1
	* Per Pin	** Not applicable to all models	

TWO YEAR LIMITED WARRANTY A-60 & A-70 BRAKE ACTUATOR

The actuator is guaranteed against defects in materials and workmanship under normal use and service for a period of two years after the date of trailer purchase by the first owner.

Limitations of Coverage

This warranty does not cover:

Normal wear and tear, including corrosion.

Damage caused by accidents, overload, abuse, modification or improper use of product.

This warranty is limited to defective parts replacement only. Charges for installing replacement parts, damage incurred to other equipment as well as incidental or consequential damages connected therewith are excluded. Some states do not allow the exclusion or limitation of incidental or consequential damages, so the above limitations may not apply to you.

Repair or Replacement Procedure

If a failure or defect occurs during the warranty period, promptly contact warrantor's (UFP) customer service department. Until such notice is received, warrantor will not be responsible for any repair or replacement costs. UFP, at its option, may require return of the component in question to the factory, transportation charges prepaid. UFP will replace, FREE OF CHARGE, either the entire actuator assembly or the part that proves defective, at its option. Any part found not to be defective will be returned freight collect with an explanation. Installation of parts and adjustment of brake systems MUST be performed by a skilled brake mechanic and service manual instructions must be followed.

Vehicle identification Number (VIN)

The VIN is a 17 digit number located on the trailer identification label. The label is located on the left side of the trailer. Be sure to include the VIN number in all communications with Warrantor.

Purchaser's Rights

This warranty gives you specific legal rights, and you may also have other rights which vary from state to state.

Product improvement

UFP has a policy of continuous product improvement. We reserve the right to change or improve the design of our products without assuming an obligation to modify any product previously manufactured.



135 Sunshine Lane ★ San Marcos, CA 92069
(760) 744-1610 ★ Fax (760) 744-1616 ★ www.ufpnet.com